

**TM 11-7440-268-14**

TECHNICAL MANUAL

**OPERATOR'S, ORGANIZATIONAL, DIRECT  
SUPPORT, AND GENERAL SUPPORT  
MAINTENANCE  
MANUAL**

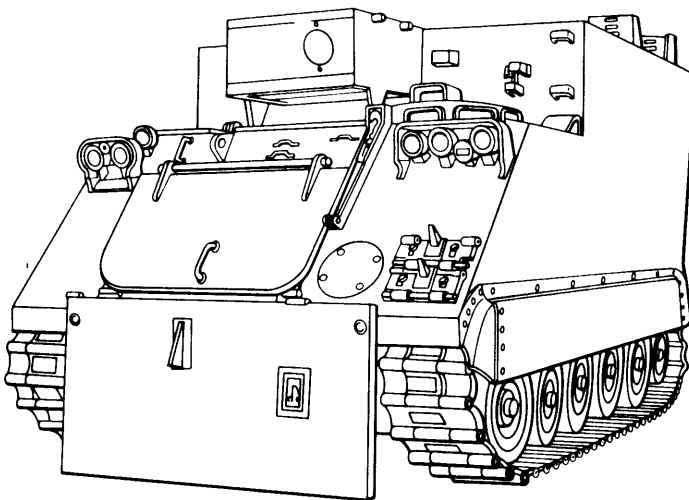

EQUIPMENT  
DESCRIPTION

1-5

ASSEMBLY AND  
INSTALLATION

4-5

REMOVAL OF  
EQUIPMENT

4-67

INDEX

Index-1

**ELECTRONICS EQUIPMENT  
INSTALLATION KIT MK-1531( )/GSG-10(V)  
IN COMMAND POST CARRIER M577A1  
(NSN 5895-01-010-5114)**

HEADQUARTERS, DEPARTMENT OF THE ARMY

23 MAY 1983



**5**

SAFETY STEPS TO FOLLOW IF SOMEONE IS THE VICTIM OF ELECTRICAL SHOCK

**1**

DO NOT TRY TO PULL OR GRAB THE INDIVIDUAL

**2**

IF POSSIBLE, TURN OFF THE ELECTRICAL POWER

**3**

IF YOU CANNOT TURN OFF THE ELECTRICAL POWER, PULL, PUSH, OR LIFT THE PERSON TO SAFETY USING A WOODEN POLE OR A ROPE OR SOME OTHER INSULATING MATERIAL

**4**

SEND FOR HELP AS SOON AS POSSIBLE

**5**

AFTER THE INJURED PERSON IS FREE OF CONTACT WITH THE SOURCE OF ELECTRICAL SHOCK, MOVE THE PERSON A SHORT DISTANCE AWAY AND IMMEDIATELY START ARTIFICIAL RESUSCITATION

**WARNING**

**HIGH VOLTAGE**

is used in the operation of this equipment.

**DEATH ON CONTACT**

May result if personnel fail to observe safety precautions.

Never work on electronic equipment unless there is another person nearby who is familiar with the operation and hazards of the equipment. When the technician is aided by an operator he must warn the operator about dangerous areas.

The power supply must be shut off before beginning work on the equipment. Always ground every part before touching it. When possible, keep one hand away from equipment to reduce the hazard of electrical shock.

Be sure equipment is always properly grounded.

When performing work on a vehicle always engage parking brake.

When welding, top off fuel tanks and purge command carrier interior.



TECHNICAL MANUAL  
No. 11-7440-268-14

HEADQUARTERS  
DEPARTMENT OF THE ARMY  
Washington, D.C., 23 May 1983

**Operator's Organizational,  
Direct Support, and General Support  
Maintenance Manual**  
for  
**ELECTRONICS EQUIPMENT INSTALLATION KIT MK-1531( )/GSG-10(V)  
IN COMMAND POST CARRIER M577A1  
(NSN 5895-01-010-5114)**

REPORTING ERRORS AND RECOMMENDING IMPROVEMENTS

You can help improve this manual. If you find any mistakes or if you know of a way to improve the procedures, please let us know. Mail your letter or DA Form 2028 (Recommended Changes to Equipment Publications and Blank Forms) or DA Form 2028-2 located in the back of this manual direct to: Commander, US Army Communications-Electronics Command and Fort Monmouth, ATTN: DRSEL-ME-MP, Fort Monmouth, New Jersey 07703. A reply will be furnished to you.

	Page
HOW TO USE THIS MANUAL .....	ii
CHAPTER 1 INTRODUCTION .....	1-1
Section I General Information .....	1-1
Section II Equipment Description .....	1-5
Section III Principles of Operation .....	1-8
CHAPTER 2 OPERATING INSTRUCTIONS .....	2-1
Section I Description and Use of Operator's Controls and Indicators .....	2-1
Section II Operator Preventive Maintenance Checks and Services .....	2-1
Section III Operation Under Usual Conditions .....	2-1
Section IV Operation Under Unusual Conditions .....	2-1
CHAPTER 3 OPERATOR MAINTENANCE .....	3-1
Section I Lubrication Instructions .....	3-1
Section II Troubleshooting Procedures .....	3-1
Section III Maintenance Procedures .....	3-1

	Page
CHAPTER 4 ORGANIZATIONAL MAINTENANCE .....	4-1
Section I Repair Parts, Special Tools, TMDE and Support Equipment. ....	4-1
Section II Service Supon Receipt .....	4-1
Section III Assembly and Installation of Electronic Equipment Kit. ....	4-5
Section IV Preventive Maintenance Checks and Services .....	4-66
Section V Organizational Troubleshooting .....	4-66
Section VI Maintenance Procedures. ....	4-66
Section VI Removal of Electronic Equipment Kit. ....	4-68
Section VII Preparation for Storage and Shipment .....	4-126
CHAPTER 5 DIRECT SUPPORT AND GENERAL SUPPORT MAINTENANCE .....	5-1
APPENDIX A REFERENCES .....	A-1
APPENDIX B MAINTENANCE ALLOCATION CHART .....	B-1
APPENDIX C COMPONENTS OF END ITEM AND BASIC ISSUE ITEMS (Not applicable)	
APPENDIX D ADDITIONAL AUTHORIZATION LIST (Not applicable)	
APPENDIX E EXPENDABLE SUPPLIES AND MATERIALS LIST (Not applicable)	
GLOSSARY .....	Glossary 1
INDEX .....	Index 1

### HOW TO USE THIS MANUAL

In this manual, paragraphs are numbered by chapter and order in each chapter. To find the paragraph you need, first locate your subject in the table of contents. Turn to the page shown and read the paragraph headings until you see what your're looking for. If you find a word or term you don't understand, refer to the glossary in the back of the book.



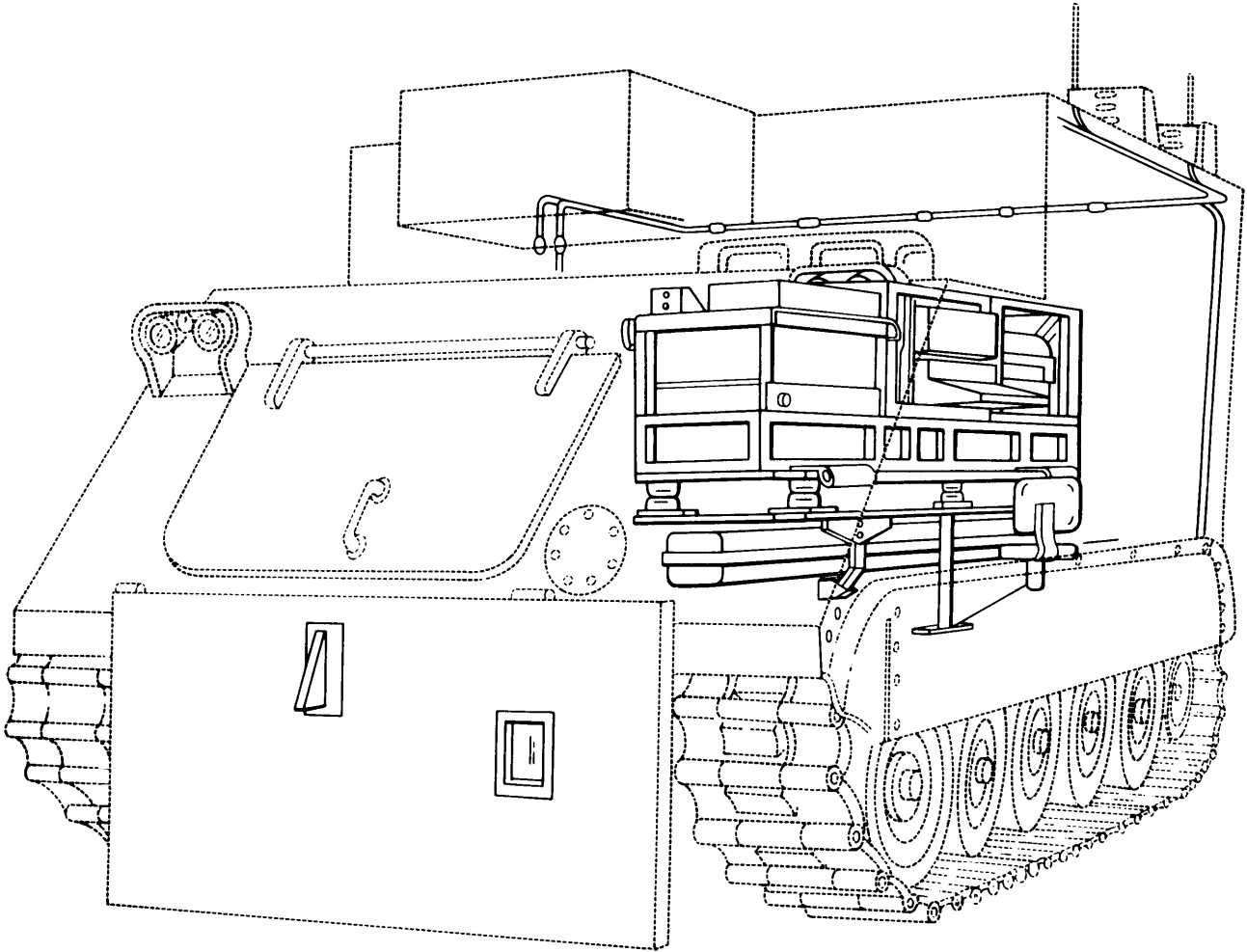

**Electronics Equipment Installation Kit MK-1531 ( )/GSG-10(V) Mounted Inside**



# CHAPTER 1

## INTRODUCTION

Subject	Section	Page
General Information .....	I	1-1
Equipment Description .....	II	1-5
Principles of Operation .....	III	1-8

### OVERVIEW

This chapter contains general information, equipment descriptions and principles of operation for Electronics Equipment Installation Kit MK-15310/GSG-10(V) in Command Post Carrier M577A1.

### Section I GENERAL INFORMATION

Subject	Para	Page
Scope .....	1-1	1-1
Maintenance Forms, Records, and Reports. ....	1-2	1-2
Consolidated Index of Army Publications and Blank Forms. ....	1-3	1-2
Destruction of Army Electronic Materiel .....	1-4	1-2
Administrative Storage .....	1-5	1-2
Reporting Equipment Improvement Recommendations .....	1-6	1-2
Nomenclature Cross Reference .....	1-7	1-3
List of Abbreviations .....	1-8	1-4

#### 1-1. SCOPE.

Type of Manual: Operator's, organizational direct support, and general support maintenance and repair.

Equipment Name and Model Number: Electronics Equipment Installation Kit MK-15310/GSG-10(V) in Command Post Carrier M577A1.

Purpose of Equipment: Provides mounting racks, hardware and cables for the installation of Variable Format Message Entry Device AN/GSC-21 in Command Post Carrier M577A1.

## **1-2. MAINTENANCE FORMS, RECORDS, AND REPORTS.**

### REPORTS OF MAINTENANCE AND UNSATISFACTORY EQUIPMENT

Department of the Army forms and procedures used for equipment maintenance will be those prescribed by TM 38-750, The Army Maintenance Management System (TAMMS).

### REPORT OF PACKAGING AND HANDLING DEFICIENCIES

Fill out and forward SF 364, Report of Discrepancy (ROD), as prescribed in AR 735-11-2/DLAR 4140.55/NAVMATINST 4355.73/AFR 400-54/MCO 4430.3E.

### DISCREPANCY IN SHIPMENT REPORT

Fill out and forward Discrepancy in Shipment Report, (DISREP) (SF 361) as prescribed in AR 55-381 NAVSUPINST 4610.33B/AFR 75-18/MCO 4610.19C/DLAR 4500.15.

## **1-3. CONSOLIDATED INDEX OF ARMY PUBLICATIONS AND BLANK FORMS.**

Refer to the latest issue of DA Pam 310-1 to determine whether there are new editions, changes or additional publications pertaining to the equipment.

## **1-4. DESTRUCTION OF ARMY ELECTRONIC MATERIEL.**

Destruction of Army electronic materiel to prevent enemy use shall be in accordance with TM 750-244-2.

## **1-5. ADMINISTRATIVE STORAGE.**

Administrative storage of equipment issued to and used by Army activities will have preventive maintenance performed in accordance with the PMCS charts before storing. When removing the equipment from administrative storage, the PMCS should be performed to assure operational readiness. Disassembly and repacking of equipment for shipment or limited storage are covered in section VIII of chapter 4.

## **1-6. REPORTING EQUIPMENT IMPROVEMENT RECOMMENDATIONS (EIR).**

If your installation kit needs improvement, let us know. Send us an EIR. You, the user, are the only one who can tell us what you don't like about your equipment. Let us know why you don't like the design or performance. Put it on an SF 368 (Quality Deficiency Report). Mail it to: Commander, US Army Communications-Electronics Command and Fort Monmouth, ATTN: DRSEL-ME-MP, Fort Monmouth, New Jersey 07703. A reply will be furnished to you.

**1-7. NOMENCLATURE CROSS REFERENCE.**

This list contains common names used throughout this manual in place of official nomenclature.

Common Name	Official Nomenclature
bottom plate assembly	bottom plate, brackets, braces, supports, stiffener
electronic line printer rack	Electrical Equipment Rack MT-4392/GSG-10(V)
electronic equipment	message entry group, electronic line printer, key generator, power distribution box
electronic equipment racks	key generator rack, message entry group rack, electronic line printer rack
electronic equipment table	Electronic Equipment Table MT-4394/GSG-10(V)
Installation kit or MK-1531	Electronics Equipment Installation Kit MK-1531( )/GSG-10(V)
key generator rack	Electrical Equipment Rack MT-4393/GSG-10(V)
message entry group rack	Electrical Equipment Rack MT-4391/GSG-10(V)
mount assembly	Bottom plate assembly, top plate assembly, tandem cup assembly, electronic equipment table
power distribution box	Distribution Box J-3030/GSG-10(V)
rack and wall mounting assembly	message entry group rack, electronic line printer rack and wall mounting assembly
tacfire components	electronic line printer, message entry group, key generator, power distribution box

**1-7. NOMENCLATURE CROSS REFERENCE. (CONT)**

Common Name	Official Nomenclature
tacfire rack	electronic line printer rack, message entry group rack, key generator rack, electronics equipment table rack
tandem cup assembly	tandem cup mounts
top plate assembly	top plate, tandem cup assembly
wall mounting assembly	wall mounting, tandem cup assembly

**1-8. LIST OF ABBREVIATIONS.**

This list contains abbreviations used in this manual.

Abbreviation	Word or Term
elect.	electrical
ELP	electronic line printer
ft	feet
IET	internal/external tooth
in.	inch
IT	internal tooth
KG	key generator
lg	long
MEG	message entry group
sp	special purpose

## Section II EQUIPMENT DESCRIPTION

Subject	Para	Page
Purpose of Installation Kit . . . . .	1-9	1-5
Equipment Capabilities and Features . . . . .	1-10	1-5
Location and Description of Major Components. . . . .	1-11	1-6
Safety, Care, Handling. . . . .	1-12	1-8

**1-9. PURPOSE OF INSTALLATION KIT.**

Provides mounting racks and power connections for electronic equipment.

**1-10. EQUIPMENT CAPABILITIES AND FEATURES.**

Provides an all weather land transportable mobile system for secure field voice and teletype communications.

1-11. LOCATION AND DESCRIPTION OF MAJOR COMPONENTS.

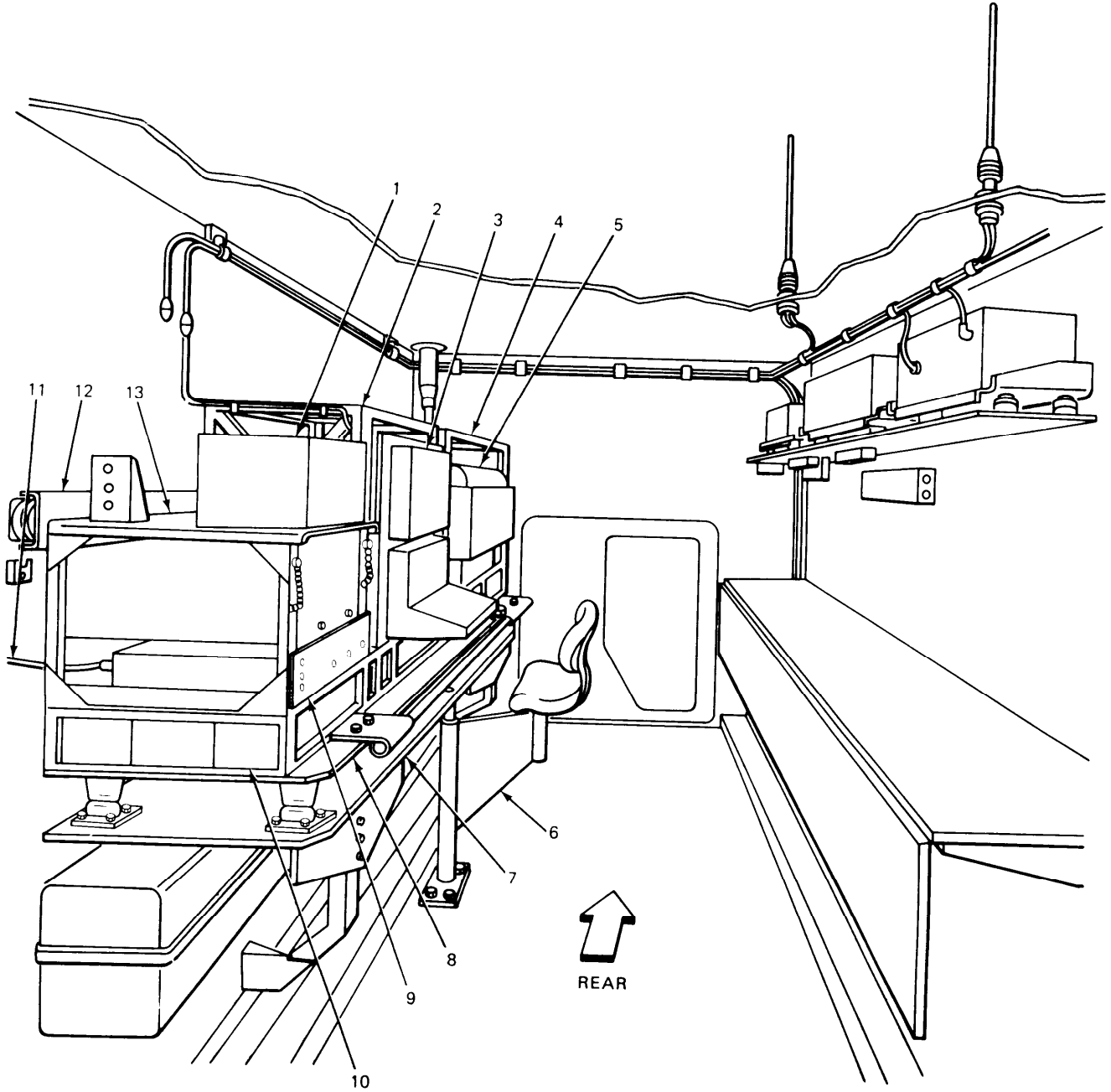

EL8KH002

**1-11. LOCATION AND DESCRIPTION OF MAJOR COMPONENTS. (CONT)**

## CURBSIDE WALL

- 1 KEY GENERATOR. Communication security equipment.
- 2 MESSAGE ENTRY GROUP RACK. Provides a housing and support for message entry group.
- 3 MESSAGE ENTRY GROUP. Groups incoming messages to produce a word or words.
- 4 ELECTRONIC LINE PRINTER RACK. Provides a housing and support for electronic line printer.
- 5 ELECTRONIC LINE PRINTER. Teletypewriter.
- 6 SEAT ASSEMBLY. Provides a seat for the operator of electronic equipment.
- 7 BOTTOM PLATE ASSEMBLY. Provides a base and support for the top plate assembly.
- 8 TOP PLATE ASSEMBLY. Provides a mounting base for the tacfire rack.
- 9 POWER DISTRIBUTION BOX. Distributes input power to electronic equipment.
- 10 ELECTRONIC EQUIPMENT TABLE. Provides a mount and support for electronic equipment racks.
- 11 POWER CABLE. Routes input power to power distribution box.
- 12 WALL MOUNTING ASSEMBLY. Provides rear support for tacfire rack.
- 13 KEY GENERATOR RACK. Provides a housing and support for key generator and power distribution box.

**1-12. SAFETY, CARE, AND HANDLING.**

Be sure to obey all WARNINGS and CAUTIONS given in this manual. Serious injury to personnel or damage to equipment may result if WARNINGS and CAUTIONS are not followed exactly.

**Section III PRINCIPLES OF OPERATION**

Subject	Para	Page
Principles of Operation . . . . .	1-13	1-8

**1-13. PRINCIPLES OF OPERATION.**

Refer to TM 11-7440-251-10 and TM 11-7440-253-10-1 for principles of operation for the electronic equipment housed in the installation kit.



## CHAPTER 2

### OPERATING INSTRUCTIONS

Subject	Section	Page
Description and Use of Operator's Controls and Indicators. . . . .	I	2-1
Operator Preventive Maintenance Checks and Services . . . . .	II	2-1
Operation Under Usual Conditions. . . . .	III	2-1
Operation Under Unusual Conditions . . . . .	IV	2-1

**OVERVIEW**

This chapter contains description and use of operator's controls and indicators, preventive maintenance checks and services, and operation under usual and unusual conditions for the electronic equipment provided in the installation kit.

**Section I DESCRIPTION AND USE OF OPERATOR'S CONTROLS AND INDICATORS**

For operating instructions of the tacfire electronic equipment, refer to TM 11-7440-251-10 and TM 11-7440-253-10-1.

**Section II OPERATOR PREVENTIVE MAINTENANCE CHECKS AND SERVICES**

There are no operator PMCS procedures for this equipment. Routine checks like equipment inventory, cleaning the vehicle, checking for frayed or broken cables, replacing items not in use, and checking for loose hardware such as nuts, bolts and screws are not listed in the PMCS table. Do these tasks daily.

**Section III OPERATION UNDER USUAL CONDITIONS**

For operation under usual conditions refer to TM 11-7440-251-10 and TM 11-7440-253-10-1.

**Section IV OPERATION UNDER UNUSUAL CONDITIONS**

For operation under unusual conditions refer to TM 11-7440-251-10 and TM 11-7440-253-10-1.



## CHAPTER 3

### OPERATOR MAINTENANCE

Subject	Section	Page
Lubrication Instructions . . . . .	I	3-1
Troubleshooting Procedures . . . . .	II	3-1
Maintenance Procedures . . . . .	III	3-1

**OVERVIEW**

This chapter contains Lubrication, troubleshooting and maintenance instructions for the electronic equipment in the installation kit.

#### Section I LUBRICATION INSTRUCTIONS

There are no lubrications instructions for the installation kit.

#### Section II TROUBLESHOOTING PROCEDURES

For troubleshooting procedures refer to TM 11-7440-251-10 and TM 11-7440-253-10-1.

#### Section III MAINTENANCE PROCEDURES

For maintenance procedures refer to TM 11-7440-251-10 and TM 11-7440-253-10-1.



## CHAPTER 4

### ORGANIZATIONAL MAINTENANCE

Subject	Section	Page
Repair Parts, Special Tools, TMDE, and Support Equipment . . . . .	I	4-1
Service Upon Receipt. . . . .	II	4-1
Assembly and installation of Electronic Equipment Installation Kit. . . . .	III	4-5
Preventive Maintenance Checks and Services . . . . .	IV	4-66
Organizational Troubleshooting . . . . .	V	4-66
Maintenance Procedures . . . . .	VI	4-66
Removal of Electronic Equipment Installation Kit . . . . .	VII	4-67
Preparation for Storage and Shipment . . . . .	VIII	4-126

#### OVERVIEW

This chapter contains instructions for the assembly, installation, and removal of the installation kit.

#### Section I REPAIR PARTS, SPECIAL TOOLS, TMDE, AND SUPPORT EQUIPMENT

Subject	Para	Page
Common Tools and Equipment . . . . .	4-1	4-1
Special Tools, TMDE, and Support Equipment . . . . .	4-2	4-1

##### 4-1. COMMON TOOLS AND EQUIPMENT.

The common tools and equipment needed for the installation of the electronic equipment installation kit will be listed in the Maintenance Allocation Chart (MAC) found in Appendix B, at the beginning of each installation procedure.

##### 4-2. SPECIAL TOOLS, TMDE AND SUPPORT EQUIPMENT.

For special tools, refer to Appendix B.

#### Section II SERVICE UPON RECEIPT

Subject	Para	Page
Unpacking . . . . .	4-3	4-2
Checking Unpacked Materiel . . . . .	4-4	4-4

**4-3. UNPACKING.**

This task covers:

Unpacking of installation kit and electronic equipment

INITIAL SETUP

Tools	Personnel Required
Pliers	One mechanic
Claw hammer	Equipment Condition
Shears	Equipment crated.
Pocket knife	
Materials/Parts	
None	

LOCATION	ITEM	ACTION REMARKS
----------	------	-------------------

**WARNING**

Stand to the side of each packing band when cutting.

**NOTE**

Move crated equipment to site of installation. Save cartons, filters, and blocking for future use as packing for storage.

1. Wooden crate	Packing band (1)	Using shears, cut.
2. Top cover	Nails (2)	Using claw hammer, remove.
3. Wooden crate	Top cover (3)	Remove.
4. Side cover	Nails (4)	Using claw hammer, remove.
5. Wooden crate	Side cover (5)	Remove.

**If packed for overseas, remove moisture-proof cover.**

4-3. UNPACKING. (CONT)

LOCATION	ITEM	ACTION REMARKS
----------	------	-------------------

**NOTE**

Remove cartons from crate and carefully remove components. Some parts are secured to sides of wooden crate. Using pliers, remove.

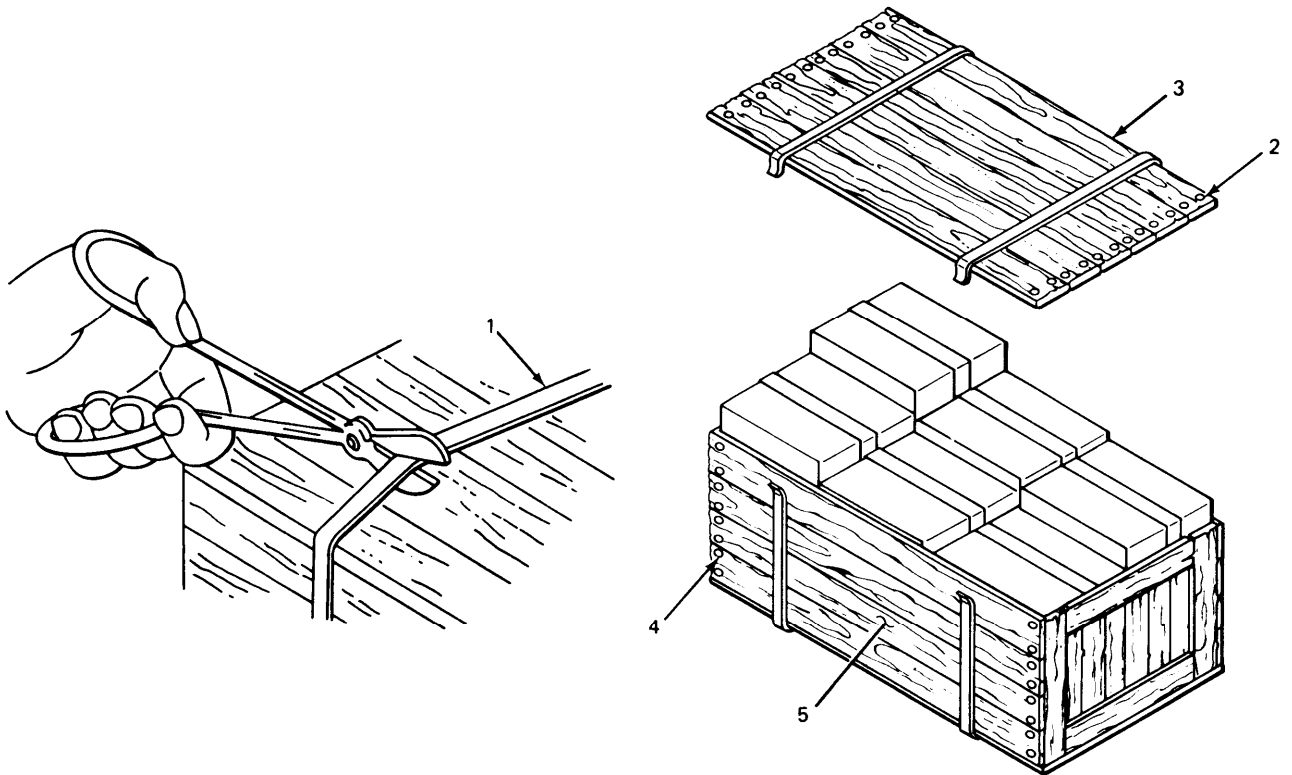

EL8KH003

#### **4-4. CHECKING UNPACKED MATERIEL.**

When the installation kit is received, the unpacker must check equipment for damage resulting from shipment, proper amount of items or parts shipped, and if the right units were sent in the installation kit.

If damage to a unit or a part of the installation kit other than minor scratches or dents are found, refer to paragraph 1-2, Maintenance Forms, Records and Reports. Check the parts list with the parts received and if there is a difference in the amount received, report on forms shown in TM 38-750. If the part numbers are not the same, check the current Modification Work Order (MWO) DA Pam 310-1 for a change in parts listing.



### Section III ASSEMBLY AND INSTALLATION OF ELECTRONICS EQUIPMENT INSTALLATION KIT

Subject	Para	Page
Overview .....		4-5
Removing Map Board. ....	4-5	4-6
Removing Rear Curbside Personnel Seat .....	4-6	4-8
Removing Rear Curbside Table. ....	4-7	4-10
Installing Rivnuts .....	4-8	4-12
Assembling Top Plate Assembly To Bottom Plate Assembly .....	4-9	4-14
Installing Mount Assembly .....	4-10	4-16
Installing Message Entry Group (MEG) rack and Electronic Line Printer (ELP) rack to Electronic Equipment Table .....	4-11	4-20
Installing Wall Mounting Assembly to MEG Rack and ELP Rack .....	4-12	4-22
Locating Wall Mounting Assembly Welding Area .....	4-13	4-24
Installing Rack and Wall Mounting Assembly .....	4-14	4-30
Installing Key Generator rack to Electronic Equipment Table and Wall Mounting Assembly. ....	4-15	4-34
Installing Seat Support Assembly and Seat .....	4-16	4-36
Installing 4 Inch Ground Straps .....	4-17	4-44
Installing Electronic Line Printer Sliding Tray. ....	4-18	4-46
Installing Tacfire Components .....	4-19	4-48
Installing 6 Inch and 15 Inch Ground Straps .....	4-20	4-52
Installing W280 Cable Assembly .....	4-21	4-54
Installing CX-13088/U and CX-13050/U Cable Assemblies .....	4-22	4-56
Installing 15 Foot Cable Assembly .....	4-23	4-58
Installing Safety Bar .....	4-24	4-60
Installing External Ground Rod Kit .....	4-25	4-62

#### OVERVIEW

Before beginning assembly of Installation Kit MK-1531 certain items should be inspected. Upon removal of curbside table, inspect wall support bracket mounting holes for rust. If rust is detected, see paragraph 4-8 for installation of rivnuts.

#### WARNING

Welding is required for this installation. Top off both fuel tanks and purge carrier interior of fumes.

**4-5. REMOVING MAP BOARD.**

This task covers:

Removal

INITIAL SETUP

Tools

Personnel Required

Pliers

One mechanic

Materials/Parts

Equipment Condition

None

Vehicle at installation site.

LOCATION	ITEM	ACTION REMARKS
1. Curbside wall in rear of vehicle	Thumb screws (1)	Loosen. Turn counterclockwise.
2.	Clamps (2)	Turn. <b>Turn both clamps until map board can be lowered.</b>
3.	Map board (3)	Remove. <b>Lift rear of map board up, remove from supports.</b>

**NOTE**

The map board when removed from carrier may be hung in covered extension. Chains are provided on back of map board for hanging.

4-5. REMOVING MAP BOARD. (CONT)

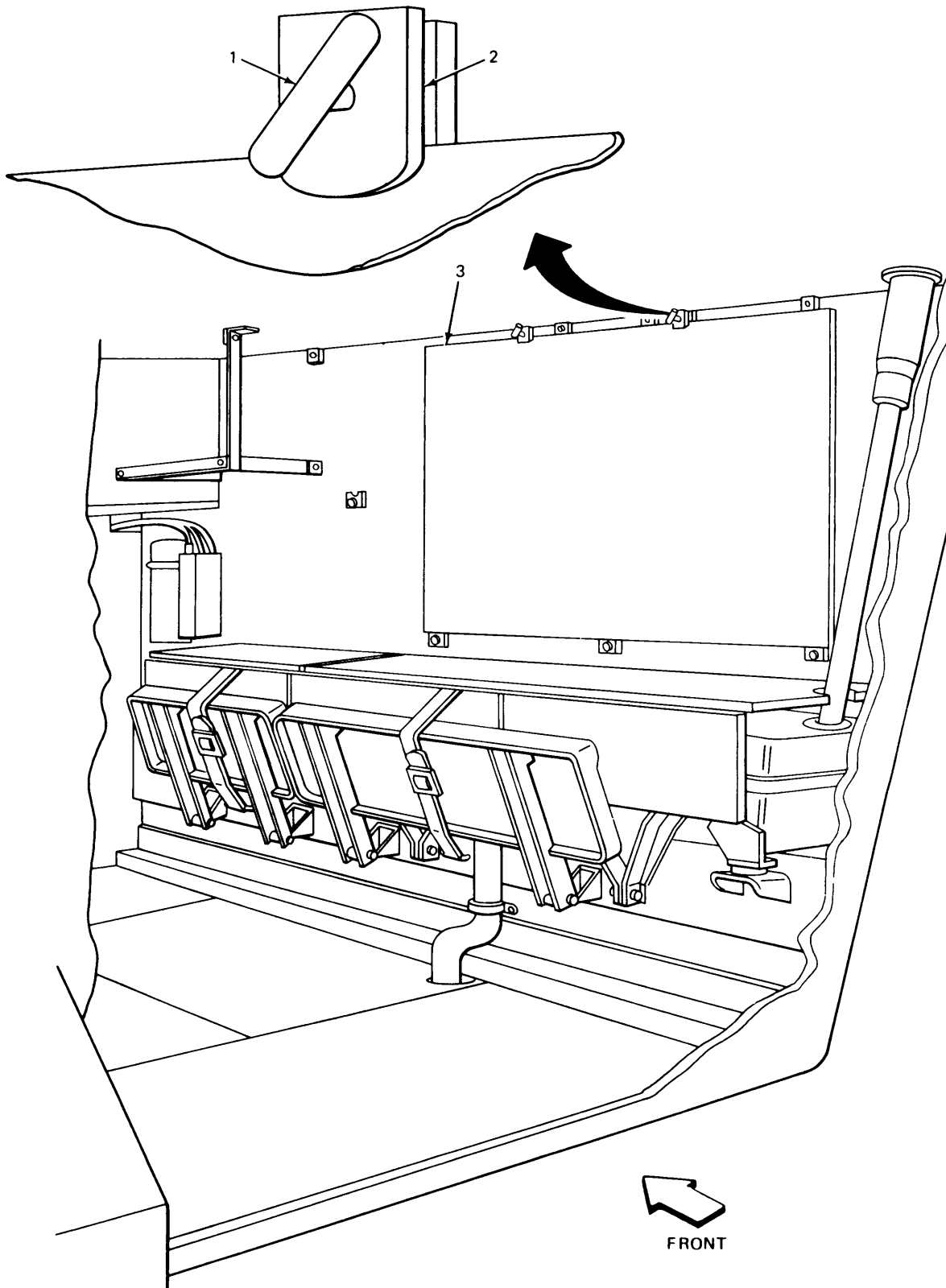

EL8KH004

**4-6. REMOVING REAR CURBSIDE PERSONNEL SEAT.**

This task covers:

Removal

INITIAL SETUP

Tools

- 3/4 inch socket
- 3/8 inch drive ratchet wrench
- 3/8 inch drive x 10 inch long extension

Materials/Parts

None

Personnel Required

One mechanic

Equipment Condition

Vehicle at installation site and all tools removed from under personnel seats.

LOCATION	ITEM	ACTION REMARKS
----------	------	-------------------

REMOVAL

1.	Curbside wall in rear of vehicle	Rear personnel seat cushion (1)	Remove.
2.		Screw (2) and flat washer (3)	Using 3/4 inch socket, extension and ratchet wrench, remove. <b>There are four screws. Step 2 is typical for all four screws.</b>
3.		Screws (4)	Do step 2 for remaining three screws. <b>Save all removed hardware.</b>
4.		Rear personnel seat (5)	Remove. <b>Store for future use.</b>

4-6. REMOVING REAR CURBSIDE PERSONNEL SEAT. (CONT)

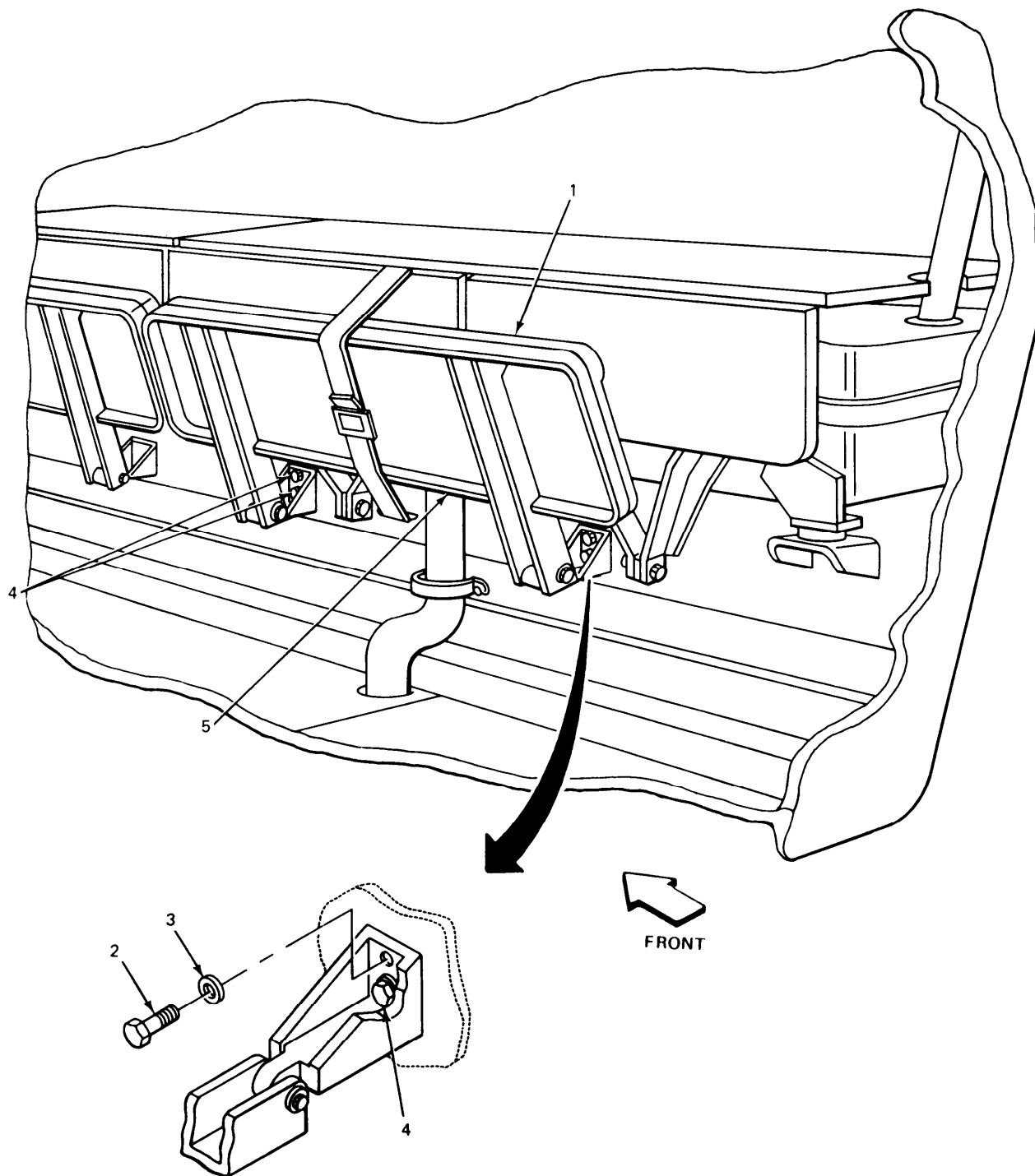

**4-7. REMOVING REAR CURBSIDE TABLE.**

This task covers:

Removal

**INITIAL SETUP**

Tools

11/16 inch box wrench  
 9/16 inch box wrench  
 7/16 inch box wrench (2 required)

Personnel Required

One mechanic

Equipment Condition

Materials/Parts

Rear personnel seat removed.  
 See paragraph 4-6.

None

LOCATION	ITEM	ACTION REMARKS
1. Curbside wall in rear of vehicle	Screw (1) and flat washer (2)	Using 9/16 inch box wrench, remove. <b>There are three screws. Step 1 is typical for all three screws.</b>
2.	Screws (3)	Do step 1 for remaining screws.
3.	Screw (4) and nut (5)	Using 9/16 inch and 11/16 inch box wrenches, remove.
4.	Screw (6) and nut (7)	Using 9/16 inch and 11/16 inch box wrenches, remove.
5.	Screw (8) and nut (9)	Using two 7/16 inch box wrenches, remove. <b>There are two screws. Step 5 is typical of both screws.</b>
6.	Screw (10)	Do step 5 again.
7.	Table (11)	Remove. <b>Store for future use.</b>

4-7. REMOVING REAR CURBSIDE TABLE. (CONT)

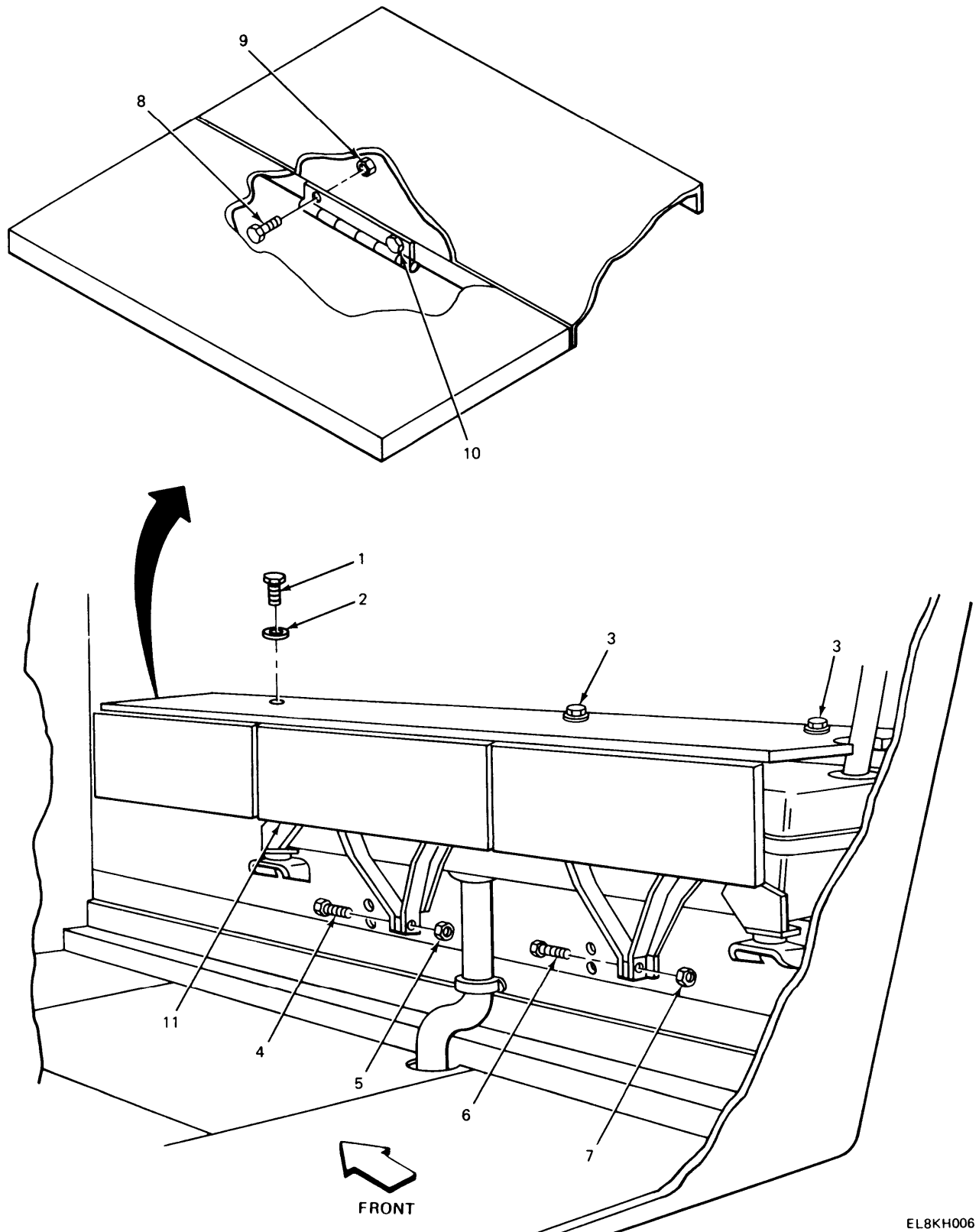

EL8KH006

**4-8. INSTALLING RIVNUTS.**

This task covers:

Installation

**INITIAL SETUP**

**Tools**

- 1/2 inch drill bit
- Electric drill
- Rivnut tool
- Adjustable wrench
- 3/8 inch hex wrench

**Personnel Required**

One mechanic

**Equipment Condition**

Table removed. See paragraph 4-7.

**Materials/parts**

3/8-16 nut, rivnut (3 required)

LOCATION	ITEM	ACTION REMARKS
----------	------	-------------------

**NOTE**

Rivnuts should only be installed if support bracket press nuts are damaged.

1. Support bracket		Using 1/2 inch drill bit and electric drill, drill out the three support bracket press nuts.
2. Pull up stud advance	Rivnut (1)	Install. <b>Screw rivnut onto pull up stud advance until rivnut is tight.</b>
3. Drilled hole	Rivnut (1)	Install. <b>Insert rivnut tool with rivnut into drilled hole.</b>
4. Top of rivnut tool	Hex wrench (2)	Install. <b>Hold still.</b>



4-8. INSTALLING RIVNUTS. (CONT)

LOCATION	ITEM	ACTION REMARKS
5. Hex nut on rivnut tool	Wrench (3)	Using adjustable wrench, turn clockwise. <b>Turn wrench 1 1/2 turns or until tight.</b>
6. Rivnut	Rivnut tool (4)	Remove. <b>Turn entire tool counterclockwise.</b>
7. Support brackets	Rivnut holes (5)	Do steps 1 thru 5 again for each rivnut.

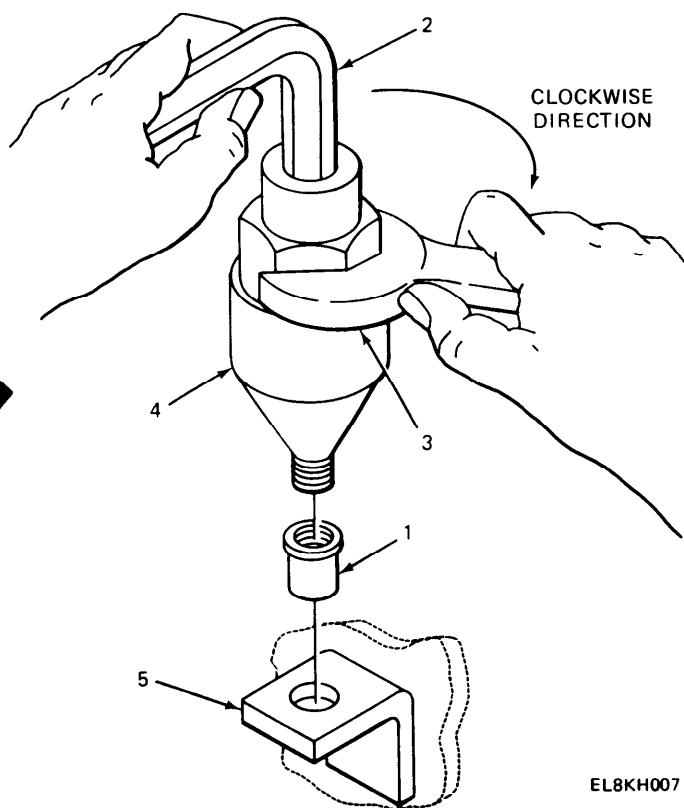
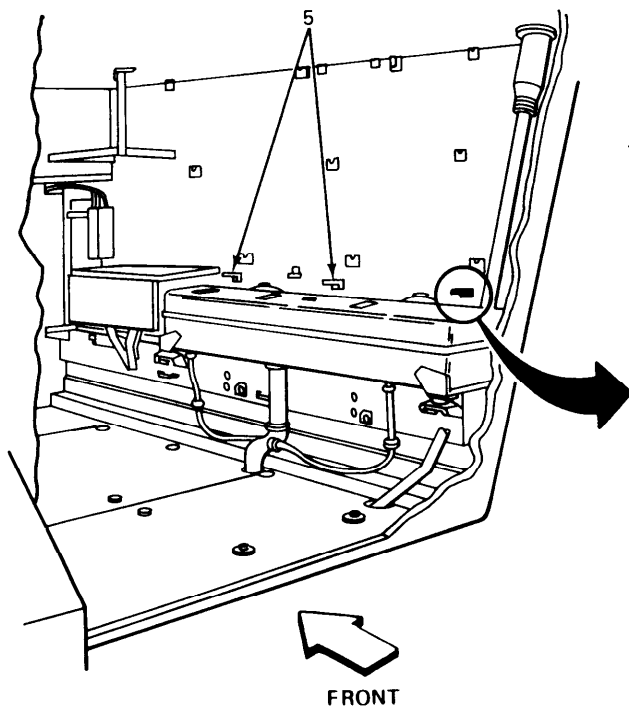

EL8KH007

**4.9. ASSEMBLING TOP PLATE ASSEMBLY TO BOTTOM PLATE ASSEMBLY.**

This task covers:

Assembly

**INITIAL SETUP**

**Tools**

9/16 inch box wrench (2 required)

**Personnel Required**

Two mechanics

**Materials/Parts**

3/8-16 x 1 1/2 inch long hex head screw (16 required)  
 3/8 inch flat washer (32 required)  
 3/8-16 self-locking nut (16 required)  
 Top plate assembly  
 Bottom plate assembly

**Equipment Condition**

Tandem cup assembly mounted to top plate assembly.

LOCATION	ITEM	ACTION REMARKS
----------	------	-------------------

**WARNING**

A helper will be needed to lift top plate assembly onto bottom plate assembly.

1. Outside of vehicle	Top plate assembly (1) and bottom plate assembly (2)	Put top plate assembly on top of bottom plate assembly and align holes of tandem cup.
2.	Screw (3), flat washers (4) and (5) and nut (6)	Install, hand tighten. <b>There are sixteen screws. Step 2 is typical for all sixteen screws.</b>
3.	Screw holes (7)	Do step 2 again.
4.	Screw (3) and nut (6)	Using two 9/16 inch box wrenches, tighten. <b>There are sixteen screws. Step 4 is typical for all sixteen screws.</b>
5.		Do step 4 for remaining fifteen screws.

4-9. ASSEMBLING TOP PLATE ASSEMBLY TO BOTTOM PLATE ASSEMBLY. (CONT)

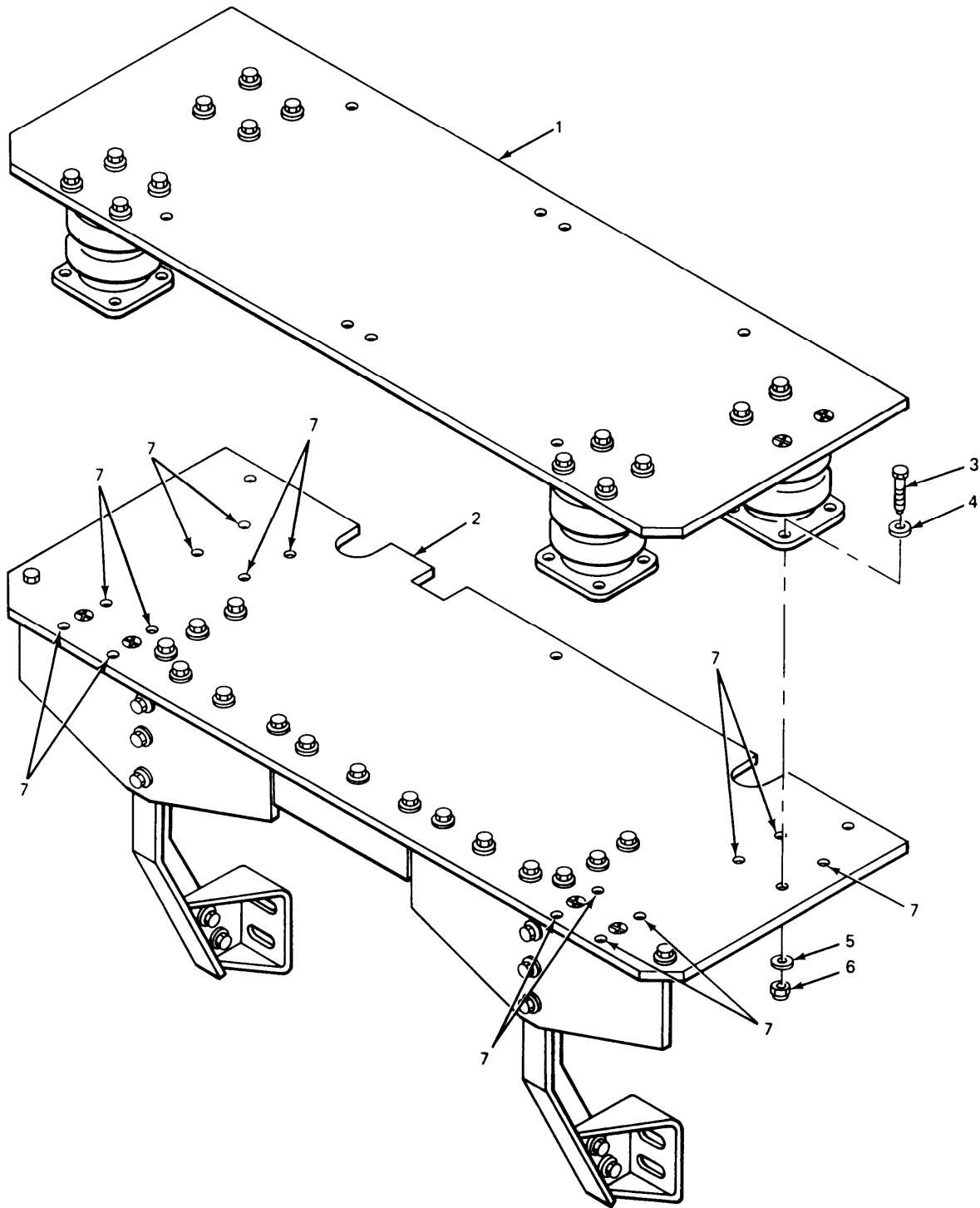

EL8KH008

**4-10. INSTALLING MOUNT ASSEMBLY.**

This task covers:

Installation

INITIAL SETUP

Tools

- 9/16 inch box wrench
- 3/4 inch box wrench

Materials/Parts

- 1/2 inch spring lockwasher (4 required)
- 3/8 -16 x 2 inch long hex head screws (3 required)
- 3/8 inch flat washer (3 required)
- 3/8 inch spring lockwasher (3 required)
- 1/16 inch thick shim (as required)
- 1/8 inch thick shim (as required)
- 1/4 inch thick shim (as required)

Materials/Parts (Cont)

Mount assembly  
All hardware previously removed and saved from personnel seat (see paragraph 4-6).

Personnel Required

Two mechanics

Equipment Condition

Map board removed. See paragraph 4-5.  
Personnel seat removed. See paragraph 4-6.  
Table removed. See paragraph 4-7.  
Top plate and bottom plate assembled. See paragraph 4-9.

LOCATION	ITEM	ACTION REMARKS
----------	------	-------------------

**WARNING**

The mount assembly requires two mechanics to lift and position.

**NOTE**

If press nuts in wall support brackets are bad, install rivnuts (see paragraph 4-8).

- |  |  |  |
|--|--|--|
| 1. Curbside wall in rear of vehicle    | Mount assembly (1)                                   | Put mount assembly into carrier and aline holes.   |
| 2. Lower curbside wall under fuel tank | Screw (2), spring lockwasher (3) and flat washer (4) | Install, hand tighten.<br><b>There are four screws. Thread screws halfway in to allow movement of mount assembly. Step 2 is typical for all four screws.</b> |
| 3.                                     | Screw holes (5)                                      | Do step 2 again.   |

4-10. INSTALLING MOUNT ASSEMBLY. (CONT)

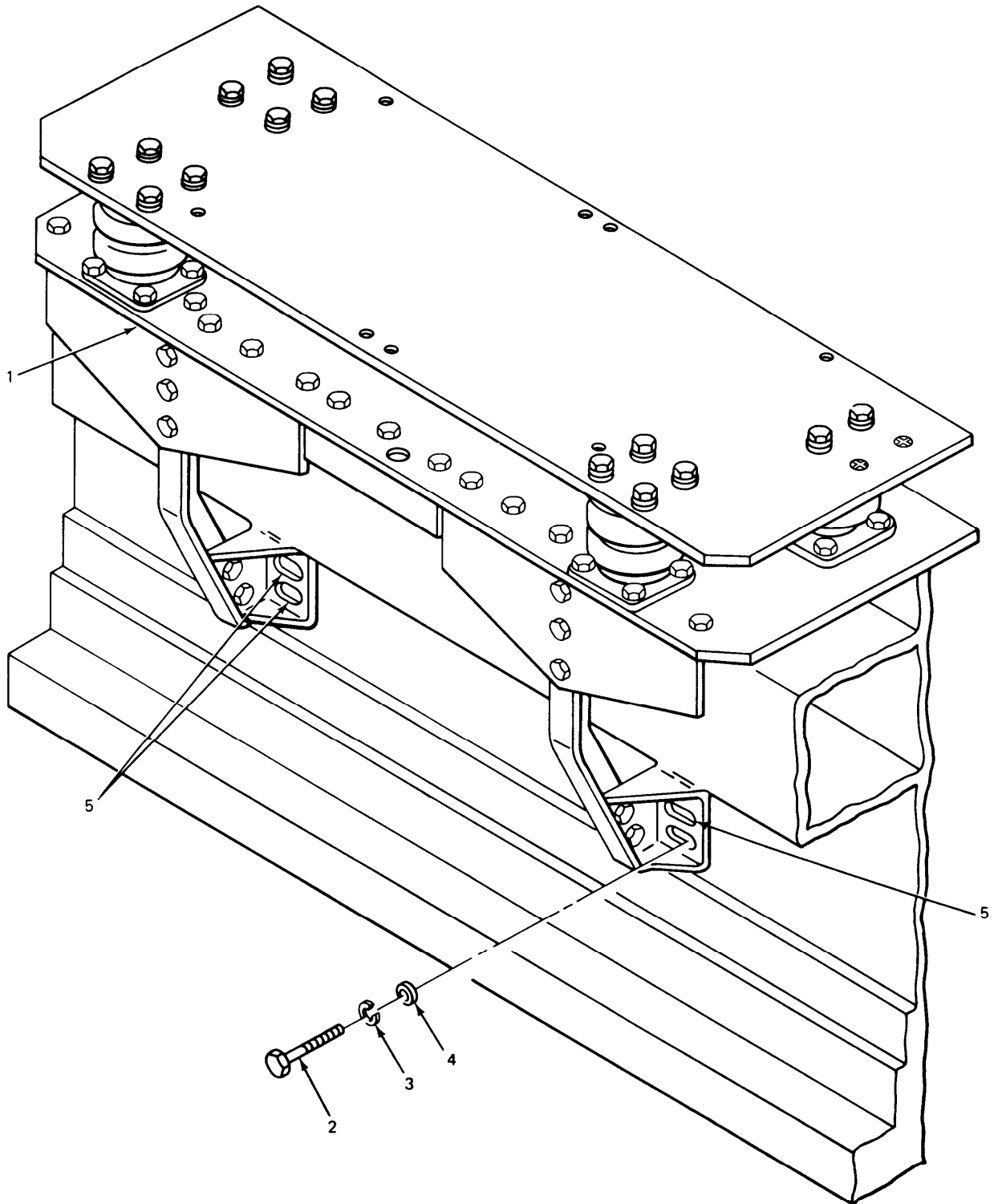

EL8KH009

4-10. INSTALLING MOUNT ASSEMBLY. (CONT)

LOCATION	ITEM	ACTION REMARKS
<b>NOTE</b>		
The mount assembly has to be level. Tilt mount assembly forward to insert shims between three bottom plate support brackets and bottom plate assembly.		
4. Curbside wall, behind	Shims (1)	Insert, aline holes. <b>Use required amount of shims to level. Tape shims together to ease in installation. There are three bottom plate support brackets. Step 4 is typical for all three bottom plate support brackets.</b>
5.	Support bracket (2)	Do step 4 again.
6.	Screw (3), flat washer (4) and spring lock-washer (5)	Install, hand tighten. <b>There are three screws. Step 6 is typical for all three screws.</b>
7.	Screw holes (6)	Do step 6 again,
8.	Screw (3)	Using 9/16 inch box wrench, tighten. <b>There are three screws. Step 8 is typical for all three screws.</b>
9.		Do step 8 for remaining screws.
10.	Screw (7)	Using 3/4 inch box wrench, tighten. <b>There are four screws. Step 10 is typical for all four screws.</b>
11.		Do step 10 for remaining three screws.

4-10. INSTALLING MOUNT ASSEMBLY. (CONT)

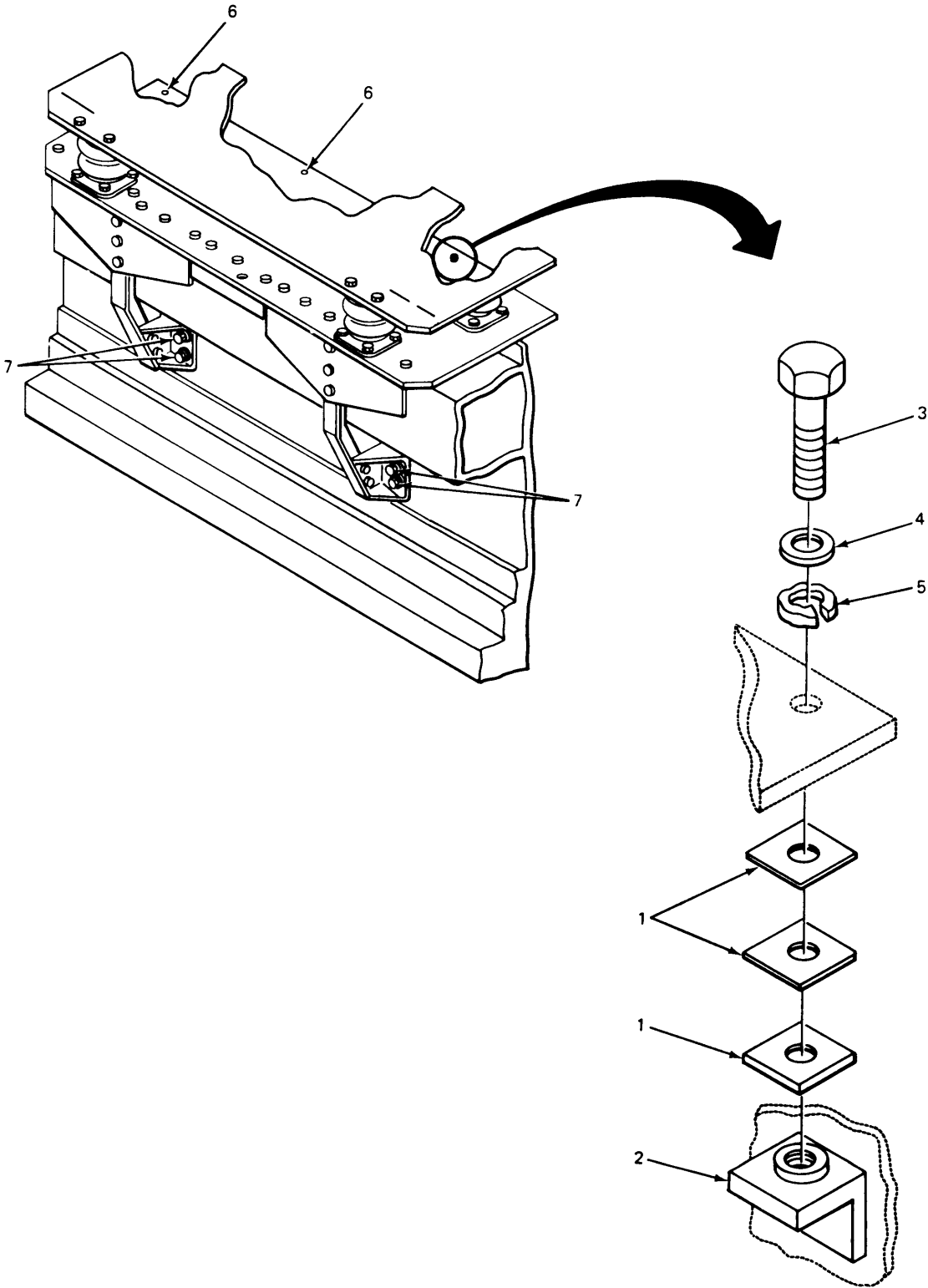

EL8KH010

**4-11. INSTALLING MESSAGE ENTRY GROUP (MEG) RACK AND ELECTRONIC LINE PRINTER (ELP) RACK TO ELECTRONIC EQUIPMENT TABLE.**

This task covers:

Installation

**INITIAL SETUP**

**Tools**

1/2 inch box wrench (2 required)

**Materials/Parts**

5/16-24 x 2 1/4 inch long hex head screw (8 required)  
 5/16-24 self-locking nut (8 required)  
 5/16 inch flat washer (16 required)  
 Message entry group rack

**Material/Parts (Cont)**

Electronic line printer rack  
 Electronic equipment table

**Personnel Required**

One mechanic

**Equipment Condition**

Top and bottom plate assembly installed.

LOCATION	ITEM	ACTION REMARKS
1. Outside vehicle	ELP rack (1) and electronic equipment table (2)	Place ELP rack on table and aline holes.
2.	Screw (3), flat washer (4), flat washer (5) and nut (6)	Install, hand tighten. <b>There are four screws. Step 2 is typical for all four screws.</b>
3.	Screw holes (7)	Do step 2 again.
4.	MEG rack (8) and electronic equipment table (2)	Place MEG rack on table and aline holes.
5.	Screw (5), flat washer (10), flat washer (11) and nut (12)	Install, hand tighten. <b>There are four screws. Step 5 is typical for all four screws.</b>
6.	Screw holes (13)	Do step 5 again.
7.	Screws (3) and screws (9)	Using two 1/2 inch box wrenches, tighten.



4-11. INSTALLING MESSAGE ENTRY GROUP (MEG) RACK AND ELECTRONIC LINE PRINTER (ELP) RACK TO ELECTRONIC EQUIPMENT TABLE. (CONT)

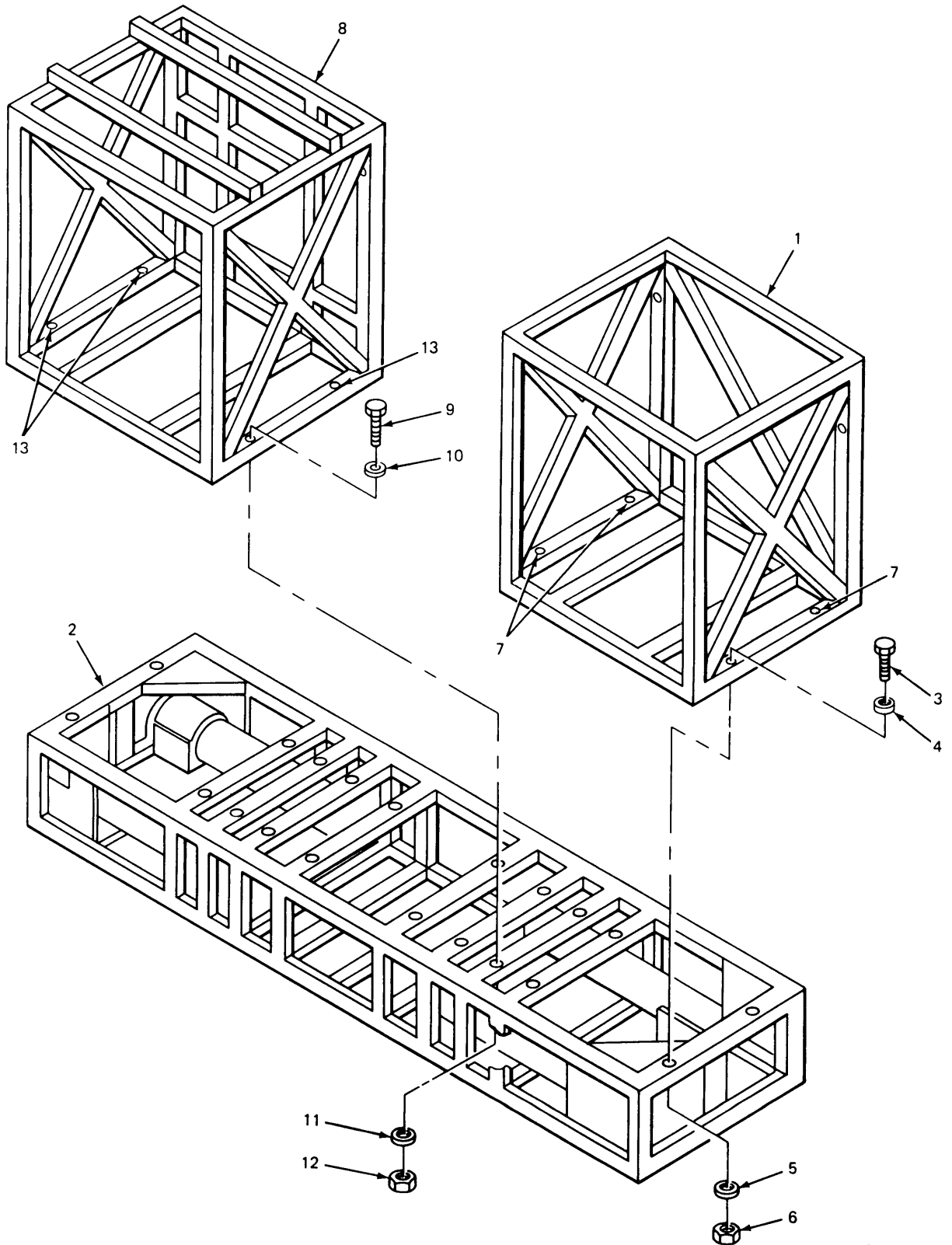

EL8KH011

**4-12. INSTALLING WALL MOUNTING ASSEMBLY TO MEG RACK AND ELP RACK.**

This task covers:

Installation

**INITIAL SETUP**

**Tools**

1/2 inch box wrench

**Personnel Required**

One mechanic

**Materials/parts**

5/16-24 x 1 1/2 inch long hex head screw (4 required)  
 5/16 inch flat washer (4 required)  
 Wall mounting assembly  
 Message entry group rack  
 Electronic line printer rack

**Equipment Condition**

Tandem cups installed on wall mounting assembly.

LOCATION	ITEM	ACTION REMARKS
1. Outside of vehicle	Wall mounting assembly (1), message entry group rack (2) and electronic line printer rack (3)	Put wall mounting assembly across rear of message entry group rack and electronic line printer rack and align holes.
2. Message Entry Group rack	Screw (4) and flat washer (5)	Install, hand tighten. <b>There are two screws. Step 2 is typical for both screws.</b>
3.	Screw hole (6)	Do step 2 again.
4. Electronic Line Printer rack	Screw (7) and flat washer (8)	Install, hand tighten. <b>There are two screws. Step 4 is typical for both screws.</b>
5.	Screw hole (9)	Do step 4 again.
6.	Screw (4) and screw (7)	Using 1/2 inch box wrench, tighten, <b>There are four screws. Step 6 is typical for all four screws.</b>

4-12. INSTALLING WALL MOUNTING ASSEMBLY TO MEG RACK AND ELP RACK. (CONT)

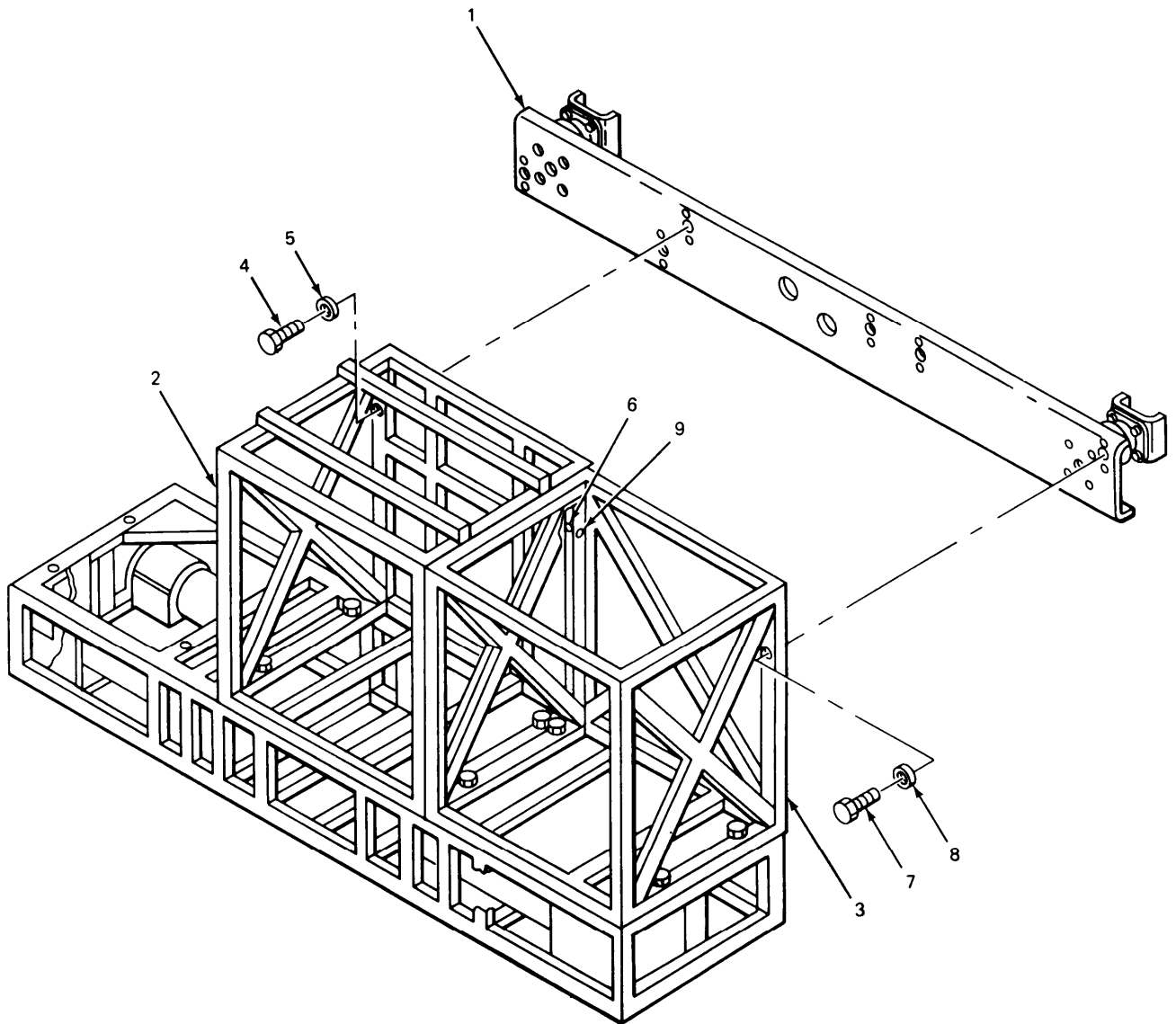

EL8KH012

**3-14. LOCATING WALL MOUNTING ASSEMBLY WELDING AREA.**

This task covers:

1. Preparation for welding
2. Welding

**INITIAL SETUP**

**Tools**

- Felt tip pen
- 7/16 inch socket
- 3/8 inch drive ratchet wrench
- 3/8 inch drive x 6 inch long extension
- Electric grinder
- 1/2 inch box wrench (2 required)

**Personnel Required**

Two mechanics

**Equipment Condition**

Racks and wall mounting assembly installed on electronic equipment table.

**Materials/parts**

- 5/16-24 x 2 1/4 inch long hex head screw (4 required)
- Rack and wall mounting assembly

**LOCATION**

**ITEM**

**ACTION**

**REMARKS**

**PREPARATION**

**WARNING**

Before any grinding or welding is started, top off both fuel tanks and purge carrier interior of fumes.

A helper will be needed to lift and position rack assembly on top of top plate assembly.

- |    |                    |                                     |   |
|----|--------------------|-------------------------------------|---|
| 1. | Top plate assembly | Rack assembly (1) and top plate (2) | Place rack assembly on top of top plate and align holes.  |
| 2. |                    | Screw (3) and table (4)             | Place screw in hole in table.<br><b>There are four screws. Step 2 is typical for all four screws.</b> |
| 3. |                    | Screw holes (5)                     | Do step 2 again.  |
| 4. |                    | Table (4)                           | Push table toward curbside wall to allow screws to drop thru holes of top plate.                      |

4-13. LOCATING WALL MOUNTING ASSEMBLY WELDING AREA. (CONT)

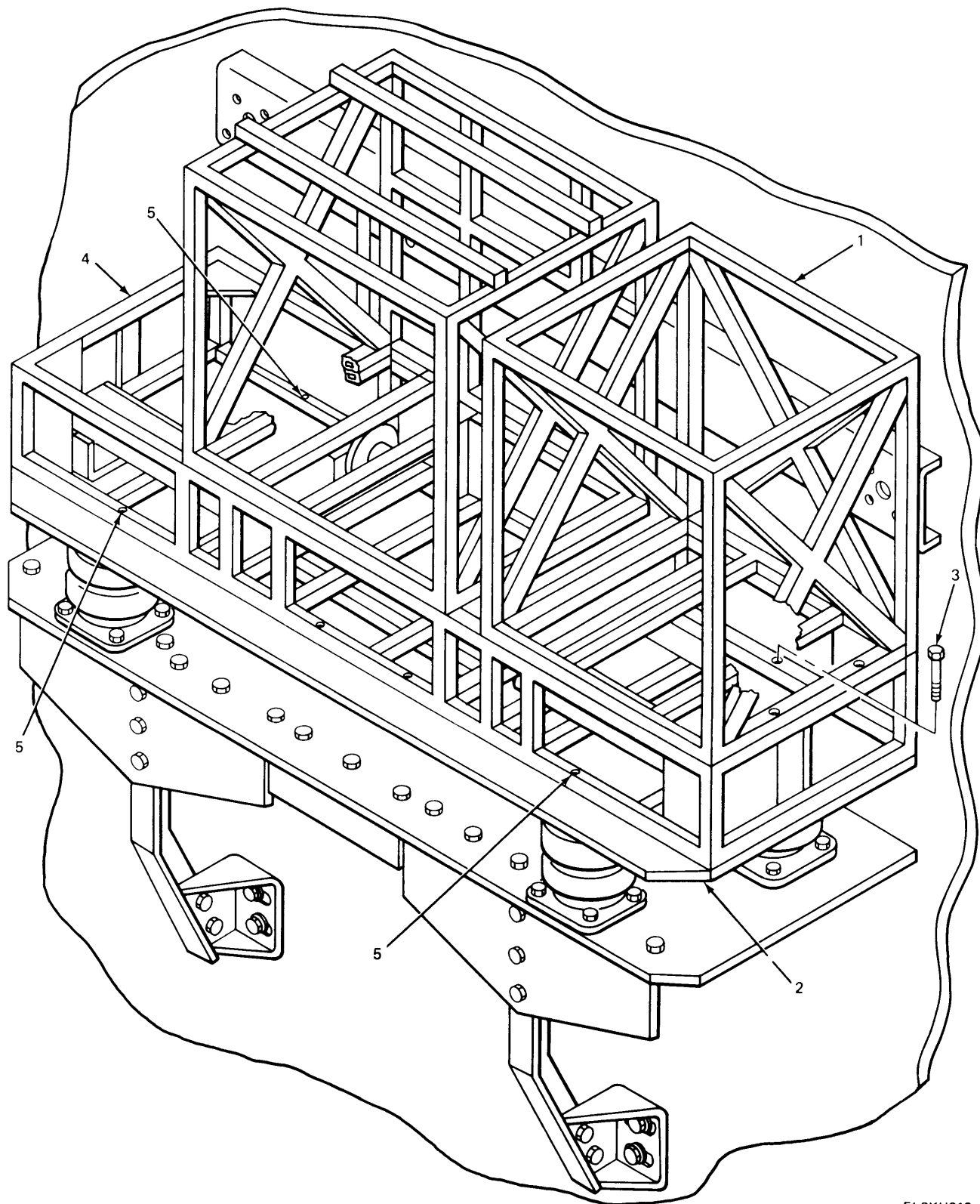

EL8KH013

4-13. LOCATING WALL MOUNTING ASSEMBLY WELDING AREA. (CONT)

LOCATION	ITEM	ACTION REMARKS
----------	------	-------------------

PREPARATION (CONT)

**NOTE**

Spacer assembly should be flush against curbside wall. If not, put shims between two halves of tandem cup mount assembly.

- |                                       |                   |  |
|---------------------------------------|-------------------|--|
| 5. Where spacer assemblies touch wall | Marks (1)         | Using felt tip pen, mark.                                    |
| 6. Table                              | Screws (2)        | Remove.  |
| 7. Top plate assembly                 | Rack assembly (3) | Remove.  |
| 8. Curbside carrier wall              | Marked areas (1)  | Using electric grinder, grind marked area free of all paint. |

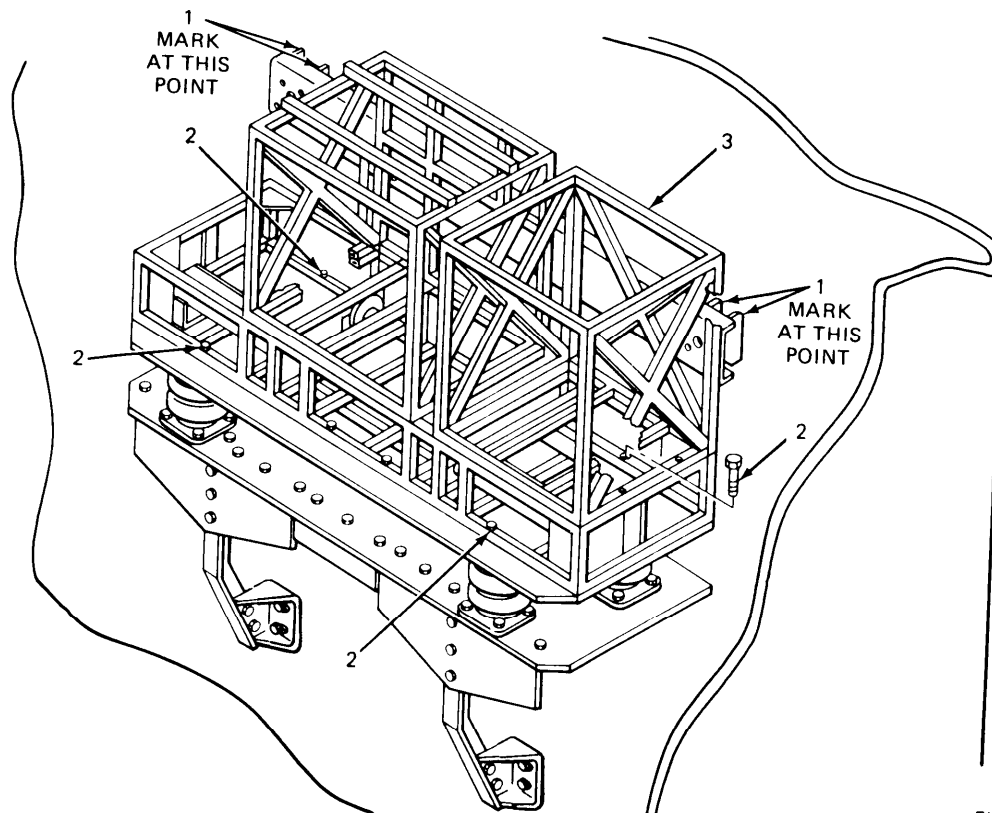

EL8KH014

4-13. LOCATING WALL MOUNTING ASSEMBLY WELDING AREA. (CONT)

LOCATION	ITEM	ACTION REMARKS
WELDING		
1. Top plate assembly	Rack assembly (1) and top plate (2)	Place rack assembly on top of top plate and aline holes.
2.	Screw (3) and table (4)	Place screw in hole and table. <b>There are four screws. Step 2 is typical for all four screws.</b>
3.	Screws (5)	Do step 2 for remaining three screws.
4.	Table (4)	Push table toward curbside wall to allow screws to drop thru into holes of top plate.

**CAUTION**

All welding must be heli-arc, refer to TM 9-237.

5. Where spacer assemblies touch wall	Spacers (6)	Tack weld both spacers to curbside carrier wall.
---------------------------------------	-------------	--

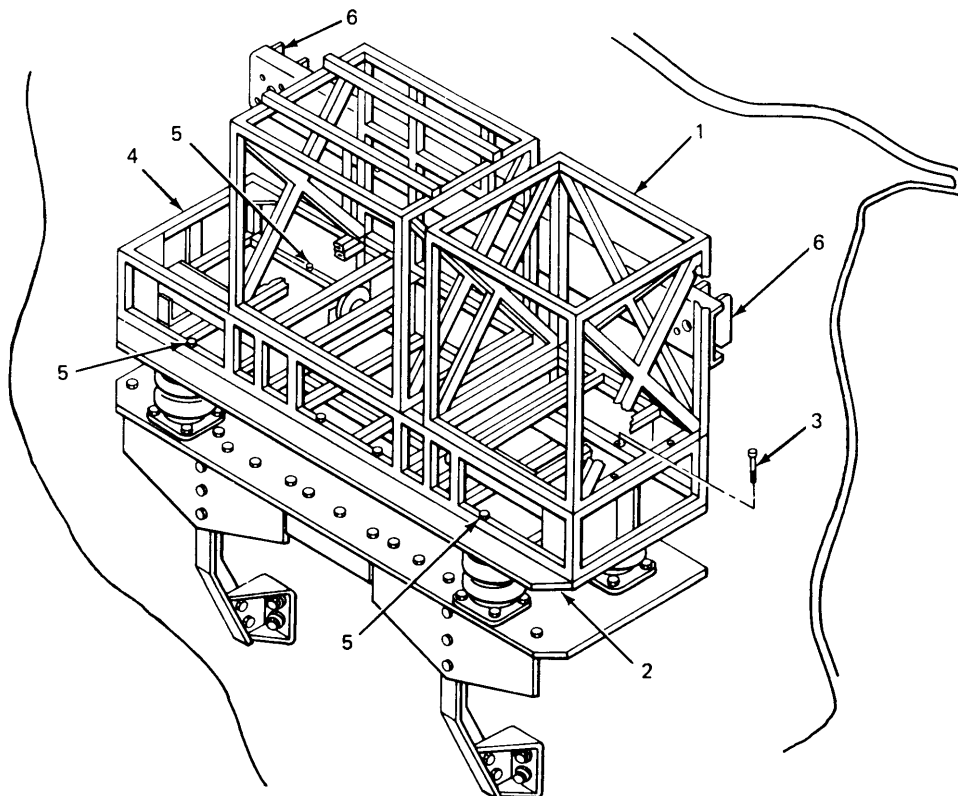

EL8KH015

4.13. LOCATING WALL MOUNTING ASSEMBLY WELDING AREA. (CONT)

LOCATION	ITEM	ACTION REMARKS
WELDING (CONT)		
6. Wall mounting assembly	Screw (1)	Using 1/16 inch socket, ratchet wrench and extension, remove. <b>There are two screws. Step 1 is typical for both screws.</b>
7.	Screw (2)	Do step 1 again. <b>Save.</b>
8. Table	Screws (3)	Remove.
9. Top plate assembly	Rack assembly (4)	Remove.
10. Curbside carrier wall	Spacer assemblies (5)	Complete welding.



4-13. LOCATING WALL MOUNTING ASSEMBLY WELDING AREA. (CONT)

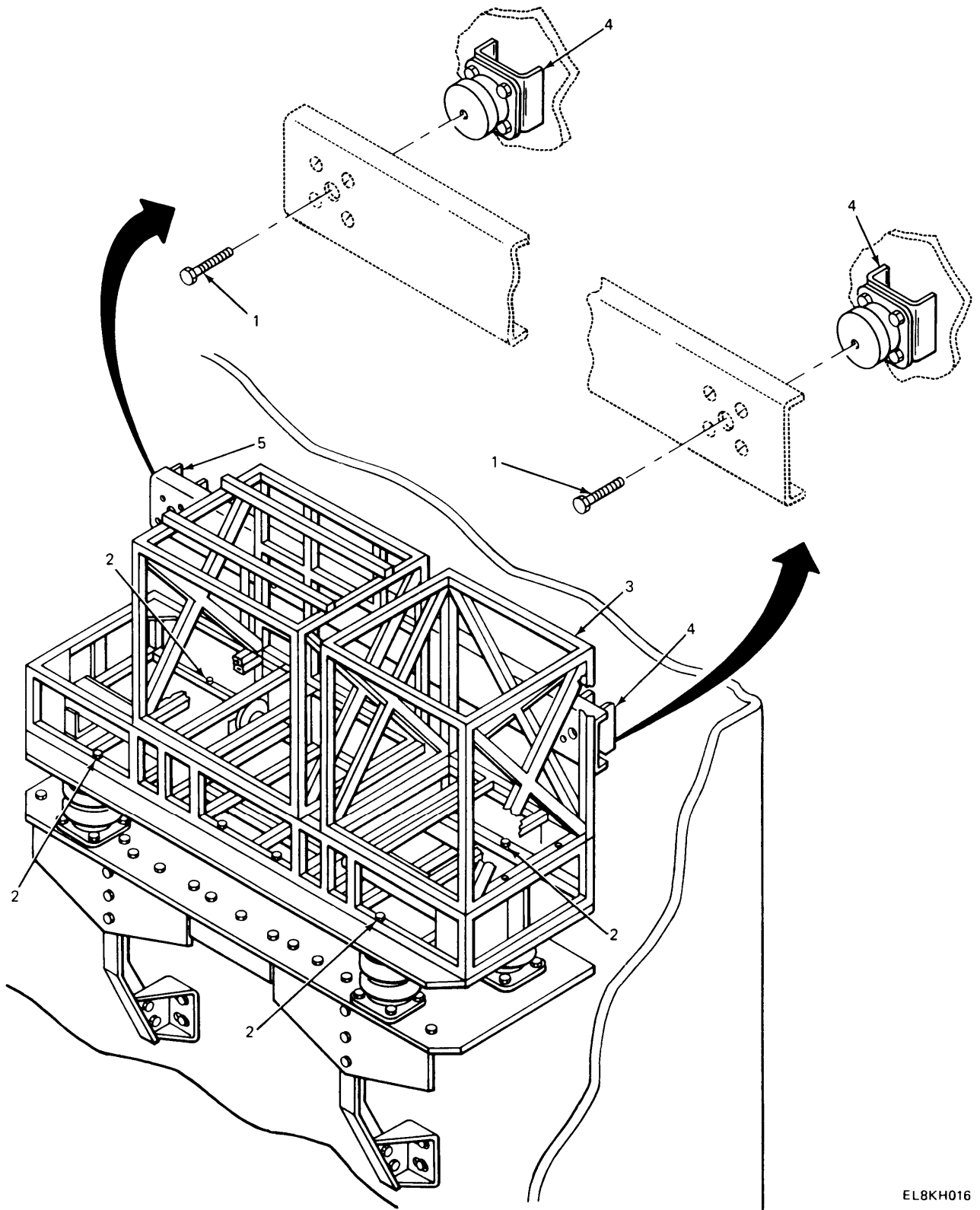

EL8KH016

**4-14. INSTALLING RACK AND WALL MOUNTING ASSEMBLY.**

This task covers:

Installation

**INITIAL SETUP**

**Tools**

- 7/16 inch socket
- 3/8 inch drive ratchet wrench
- 3/8 inch drive x 6 inch long extension
- 1/2 inch box wrench (2 required)

**Personnel Required**

Two mechanics

**Equipment Condition**

Spacer assemblies welded to carrier wall.

**Materials/Parts**

- 5/16-24 x 2 1/4 inch long hex head screw (8 required)
- 5/16 inch flat washer (16 required)
- 5/16-24 self-locking nut (8 required)

LOCATION	ITEM	ACTION REMARKS
----------	------	-------------------

**WARNING**

A helper will be needed to lift and position assembly on top plate.

- |    |                    |  |   |
|----|--------------------|--|---|
| 1. | Top plate assembly | Rack assembly (1) and top plate (2)      | Place rack assembly on top of top plate and align holes.  |
| 2. |                    | Screw (3), flat washer (4) and table (5) | Place screw in hole in table.<br><b>There are eight screws. Step 2 is typical for all eight screws.</b> |
| 3. |                    | Holes (6)                                | Do step 2 again.  |
| 4. |                    | Table (5)                                | Push table toward curbside wall to allow screws to drop thru holes of top plate.                        |
| 5. |                    | Flat washer (7) and nut (8)              | Install.<br><b>There are eight nuts. Step 5 is typical for all eight nuts.</b>                          |
| 6. |                    |  | Do step 5 for remaining seven nuts.   |

4-14. INSTALLING RACK AND WALL MOUNTING ASSEMBLY. (CONT)

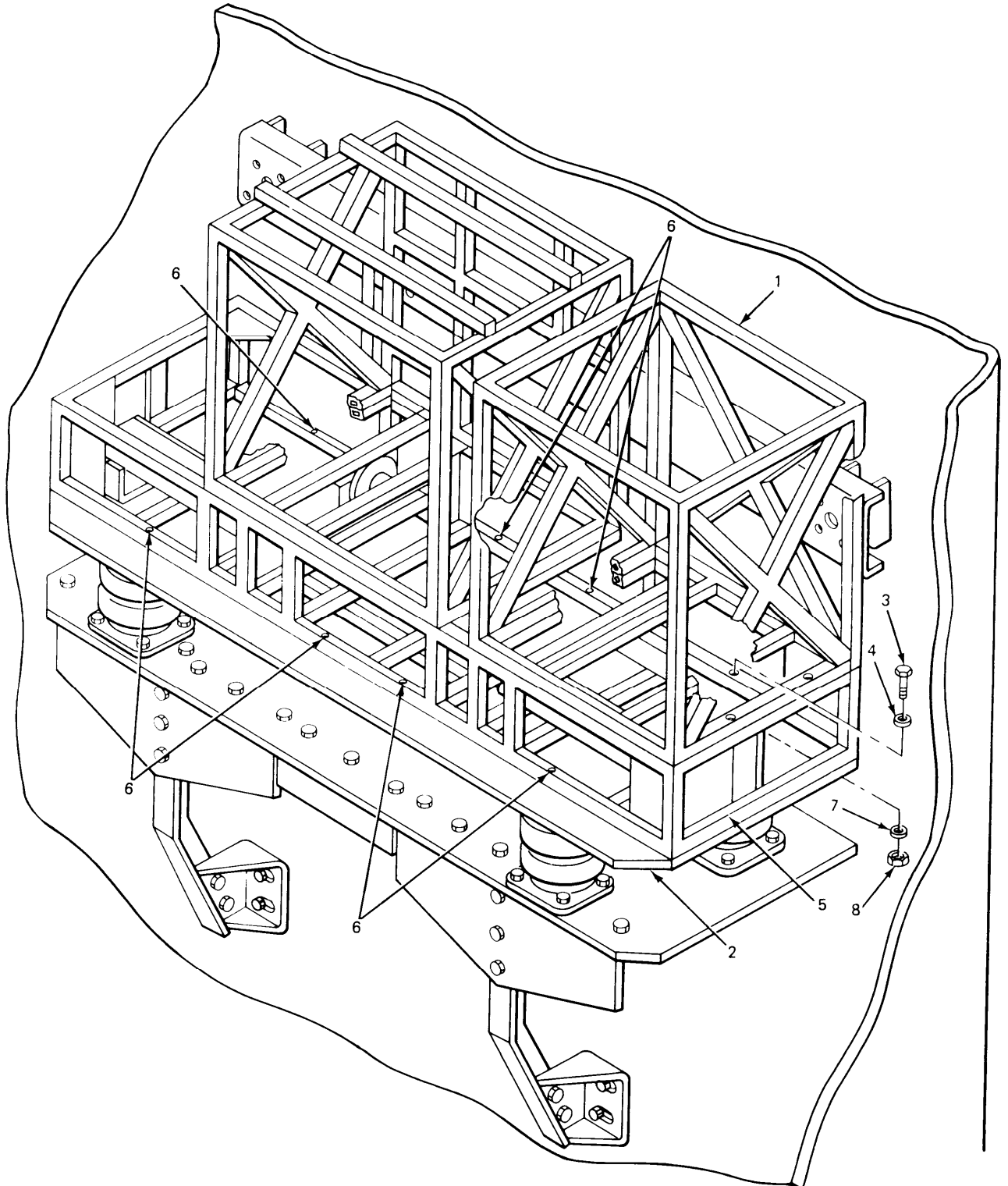

EL8KH017

4-14. INSTALLING RACK AND WALL MOUNTING ASSEMBLY. (CONT)

LOCATION	ITEM	ACTION REMARKS
7. Curbside carrier wall	Wall mounting assembly (1) and spacer (2)	Align.
8. Wall mounting assembly	Screw (3)	Install. <b>There are two screws. Steps 7 and 8 are typical for both screws.</b>
9.	Screw (4)	Do steps 7 and 8 again.

4-14. INSTALLING RACK AND WALL MOUNTING ASSEMBLY. (CONT)

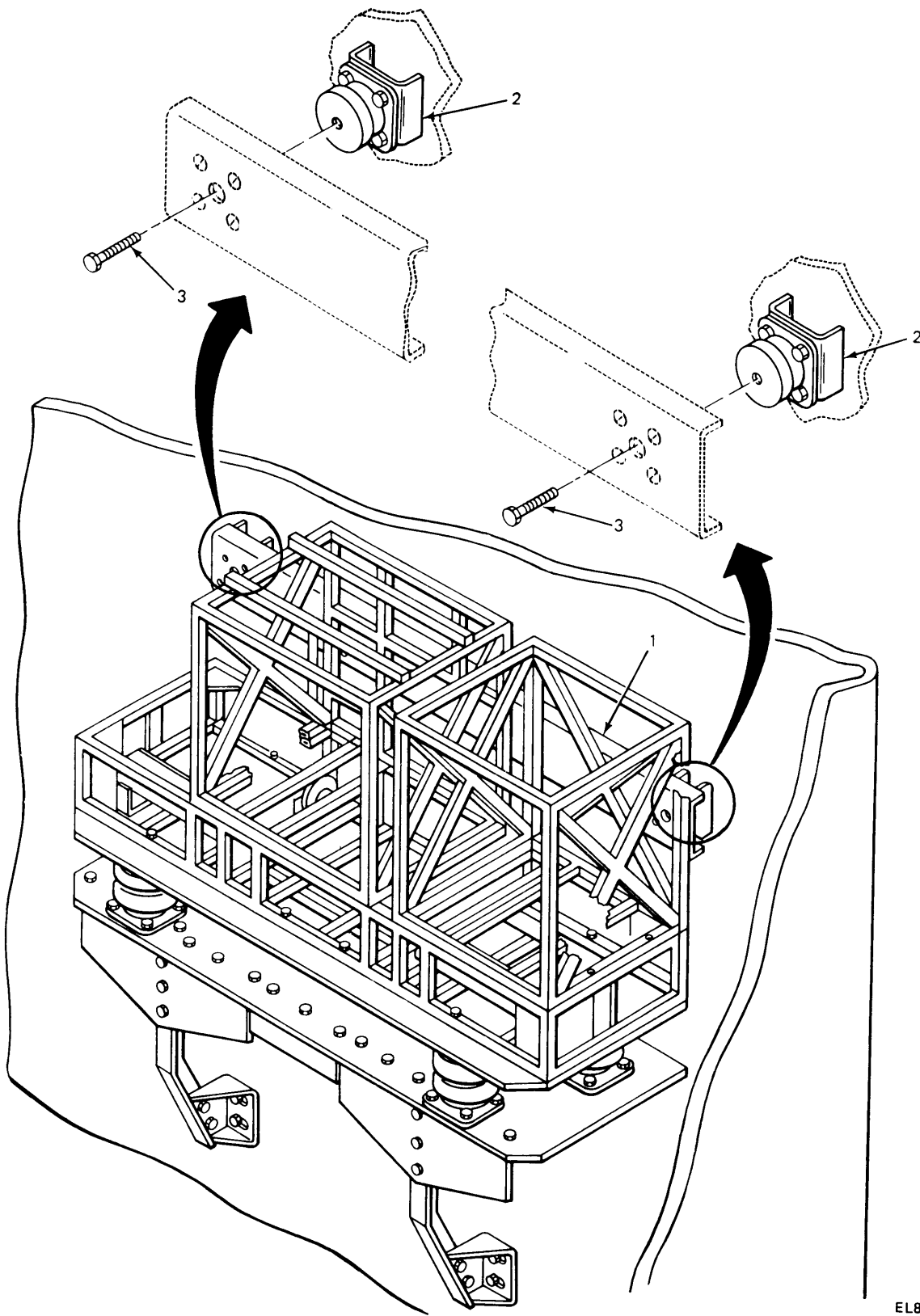

EL8KH018

**4-15. INSTALLING KEY GENERATOR RACK TO ELECTRONIC EQUIPMENT TABLE AND WALL MOUNTING ASSEMBLY.**

This task covers:

Installation

**INITIAL SETUP**

**Tools**

1/2 inch box wrench  
(2 required)  
Hammer

**Materials/parts**

5/16-24 x 2 1/4 inch long hex  
head screw (4 required)  
5/16 inch flat washer (8 required)  
5/16-24 self-locking nut (4 required)  
Key generator rack

**Materials/parts (Cont)**

Saved hardware from wall  
mounting assembly

**Personnel Required**

One mechanic

**Equipment Condition**

Rack and wall mounting  
assembly installed.  
See paragraph 4-15.

LOCATION	ITEM	ACTION REMARKS
1. Mount assembly	Key generator rack (1) and electronic equipment table (2)	Put key generator rack on top of electronic equipment table and align holes.
2.	Screw (3), flat washer (4) flat washer (5) and nut (6)	Install, hand tighten. <b>There are four screws. Step 2 is typical for all four screws.</b>
3.	Screw holes (7)	Do step 2 again.
4. Wall mounting assembly	Screw (8) and flat washer (9)	Install, hand tighten.

**NOTE**

Misalignment can be corrected by striking corner of wall mounting assembly toward rear of vehicle.

**4-15. INSTALLING KEY GENERATOR RACK TO ELECTRONIC EQUIPMENT TABLE AND WALL MOUNTING ASSEMBLY. (CONT)**

LOCATION	ITEM	ACTION REMARKS
5.	Screw (10) and flat washer (11)	Install, hand tighten.
6. Mount assembly	Screw (3) and nut (6)	Using two 1/2 inch box wrenches, tighten. <b>There are four screws. Step 6 is typical for all four screws.</b>
7.		Do step 6 for remaining three screws.
8. Wall mounting assembly	Screw (8)	Using 1/2 inch box wrench, tighten.
9.	Screw (10)	Using 1/2 inch box wrench, tighten.

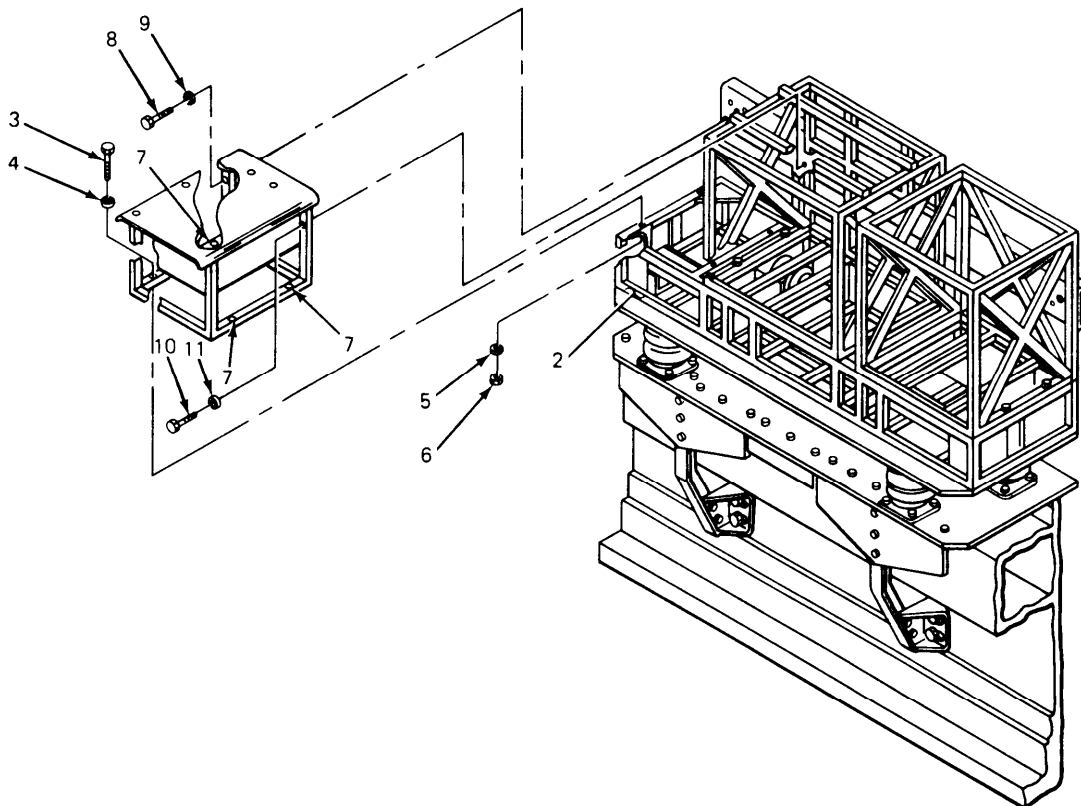

EL8KH019

**4-16. INSTALLING SEAT SUPPORT ASSEMBLY AND SEAT.**

This task covers:

Installation

**INITIAL SETUP**

**Tools**

- 3/4 inch box wrench
- 1/2 inch box wrench  
(2 required)
- Center punch
- Felt tip pen
- Flat tip screwdriver
- Electric drill
- 1/8 inch drill bit
- Q-drill bit

**Materials/Parts**

- 4 inch x 4 inch x 12 inch  
wood block
- Seat support assembly
- Seat

**Materials/Parts (Cont)**

- 5/16 24 x 2 1/4 inch long hex  
head screw (4 required)
- 5/16-24 self-locking nut  
(4 required)

**Personnel Required**

One mechanic

**Equipment Condition**

Mount assembly installed.  
See paragraph 4-10.

LOCATION	ITEM	ACTION REMARKS
1. Floor plate	Screw (1) and flat washer (2)	Using 3/4 inch box wrench, remove. <b>Save.</b>
2. Bottom plate	Seat support assembly (3)	install. <b>Put top of tube in hole in bottom plate.</b>
3. Floor plate	Lower support (4)	Put on bottom of tube and place on floor plate. <b>Make sure tube is straight and floor plate is flat and level.</b>
4.	Lower support (4) and marks (5)	Using felt tip pen, mark. <b>There are four holes to mark.</b>
5.	Seat support assembly (3) and lower support (4)	Remove.



4-16. INSTALLING SEAT SUPPORT ASSEMBLY AND SEAT. (CONT)

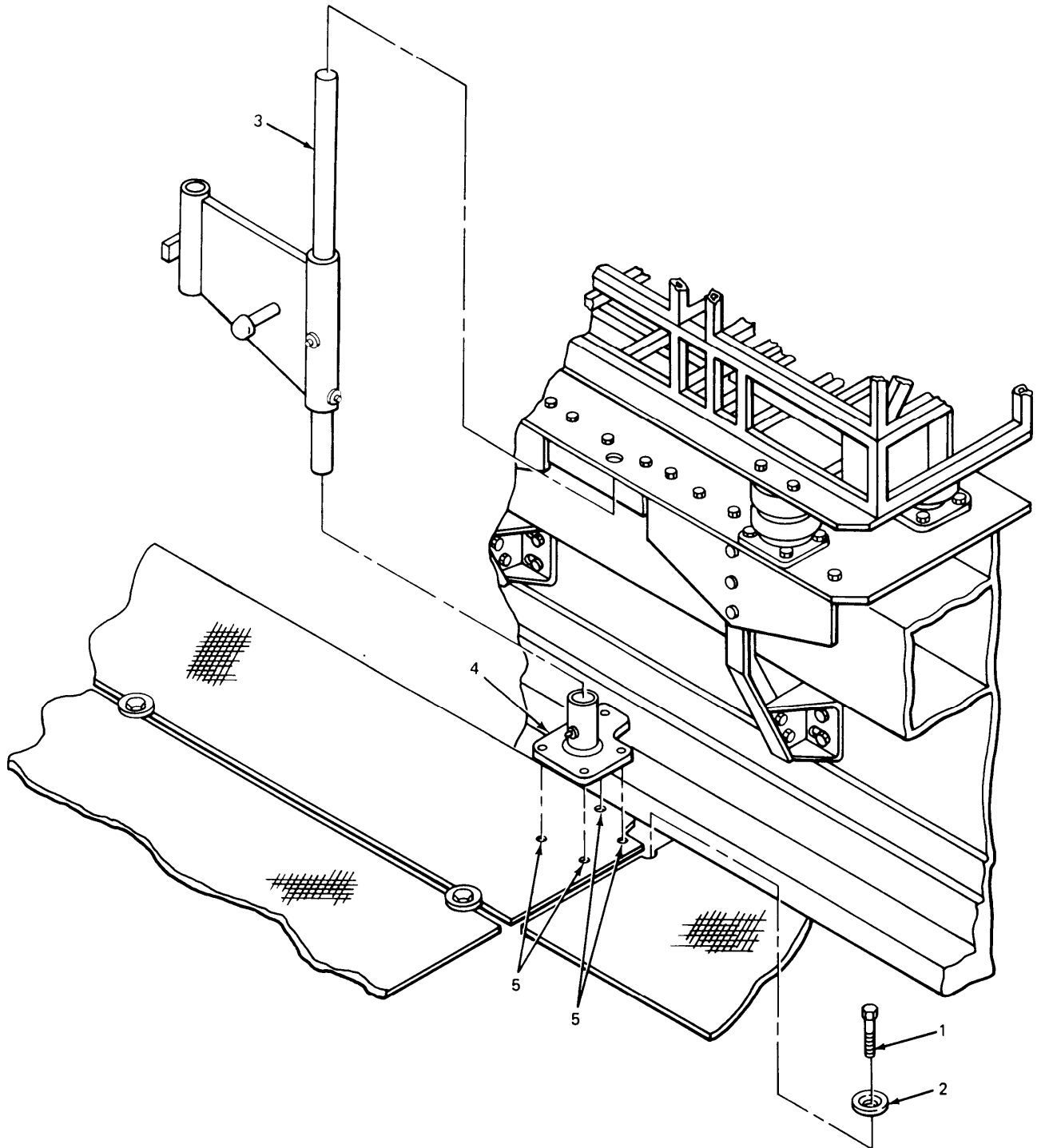

EL8KH020

4-16. INSTALLING SEAT SUPPORT ASSEMBLY AND SEAT. (CONT)

LOCATION	ITEM	ACTION REMARKS
6. Floor plate	Screw (1) and flat washer (2)	Using 3/4 inch box wrench, remove. <b>There are three screws. Step 6 is typical for all three screws.</b>
7.	Screws (3)	Do step 6 again.
8.	Marks (4)	Using center punch, punch.
9.	Wood block (5)	Raise edge of floor plate and install.
<b>CAUTION</b>		
<b>Care must be taken not to drill too deep as not to drill through hydraulic lines positioned under floor plate.</b>		
10.	Marks (4)	Using electric drill and 1/8 inch drill bit, drill.
11.	Marks (4)	Using electric drill and Q-drill bit, drill.

4-16. INSTALLING SEAT SUPPORT ASSEMBLY AND SEAT. (CONT)

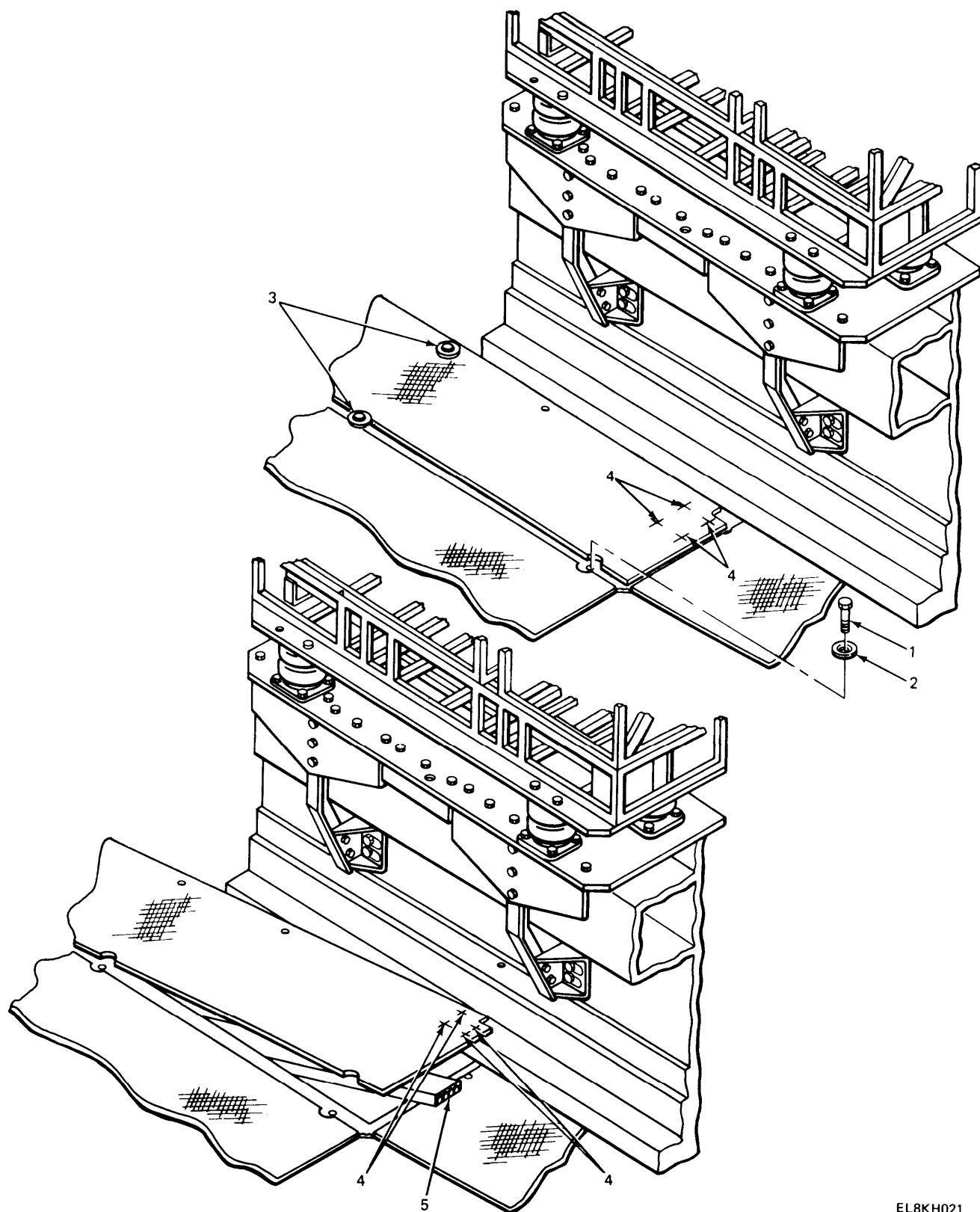

EL8KH021

4-16. INSTALLING SEAT SUPPORT ASSEMBLY AND SEAT. (CONT)

LOCATION	ITEM	ACTION REMARKS
12. Floor plate	Lower support (1)	Place on floor plate and align holes.
13.	Screw (2), and nut (3)	Using two 1/2 inch box wrenches, install. <b>There are four screws. Step 13 is typical for all four screws.</b>
14.	Screw holes (4)	Do step 13 again.
15.	Wood block (5)	Remove. <b>Throw away.</b>
16.	Screw (6) and flat washer (7)	Using 3/4 inch box wrench, install. <b>There are four screws. Step 16 is typical for all four screws.</b>
17.	Screw holes (8)	Do step 16 again.

4-16. INSTALLING SEAT SUPPORT ASSEMBLY AND SEAT. (CONT)

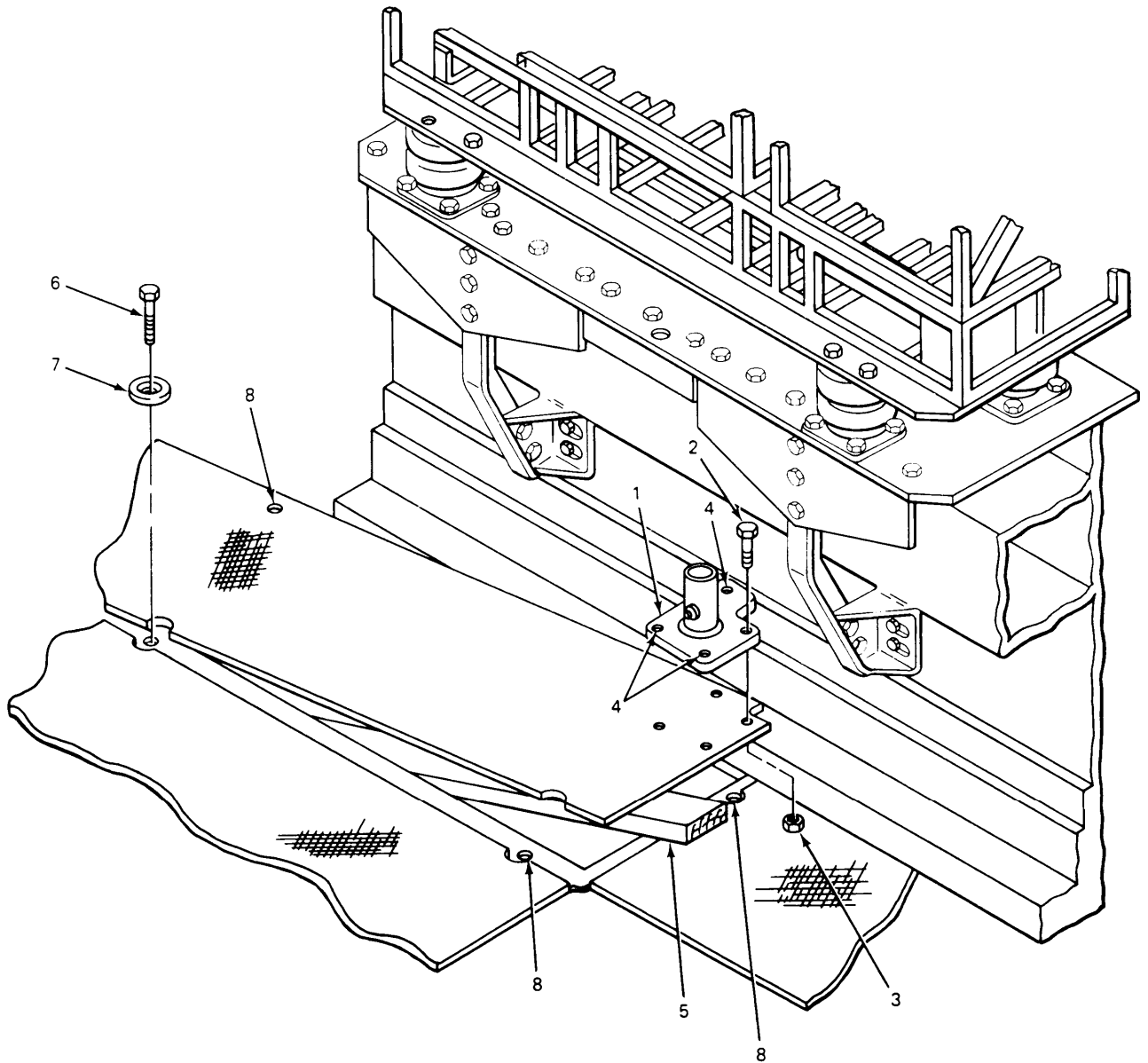

4-16. INSTALLING SEAT SUPPORT ASSEMBLY AND SEAT. (CONT)

LOCATION	ITEM	ACTION REMARKS
18. Bottom plate	Seat support assembly (1) and bottom plate hole (2)	Install. <b>Put top of tube in hole in bottom plate.</b>
19. Floor plate	Lower support (3)	Install. <b>Put bottom of tube in floor plate. Secure with quick release pins.</b>
20. Seat support assembly	Seat (4) and support tube (5)	Install. <b>Place seat post in support tube.</b>
21.	Screw (6)	Using flat tip screwdriver, install,

4-16. INSTALLING SEAT SUPPORT ASSEMBLY AND SEAT. (CONT)

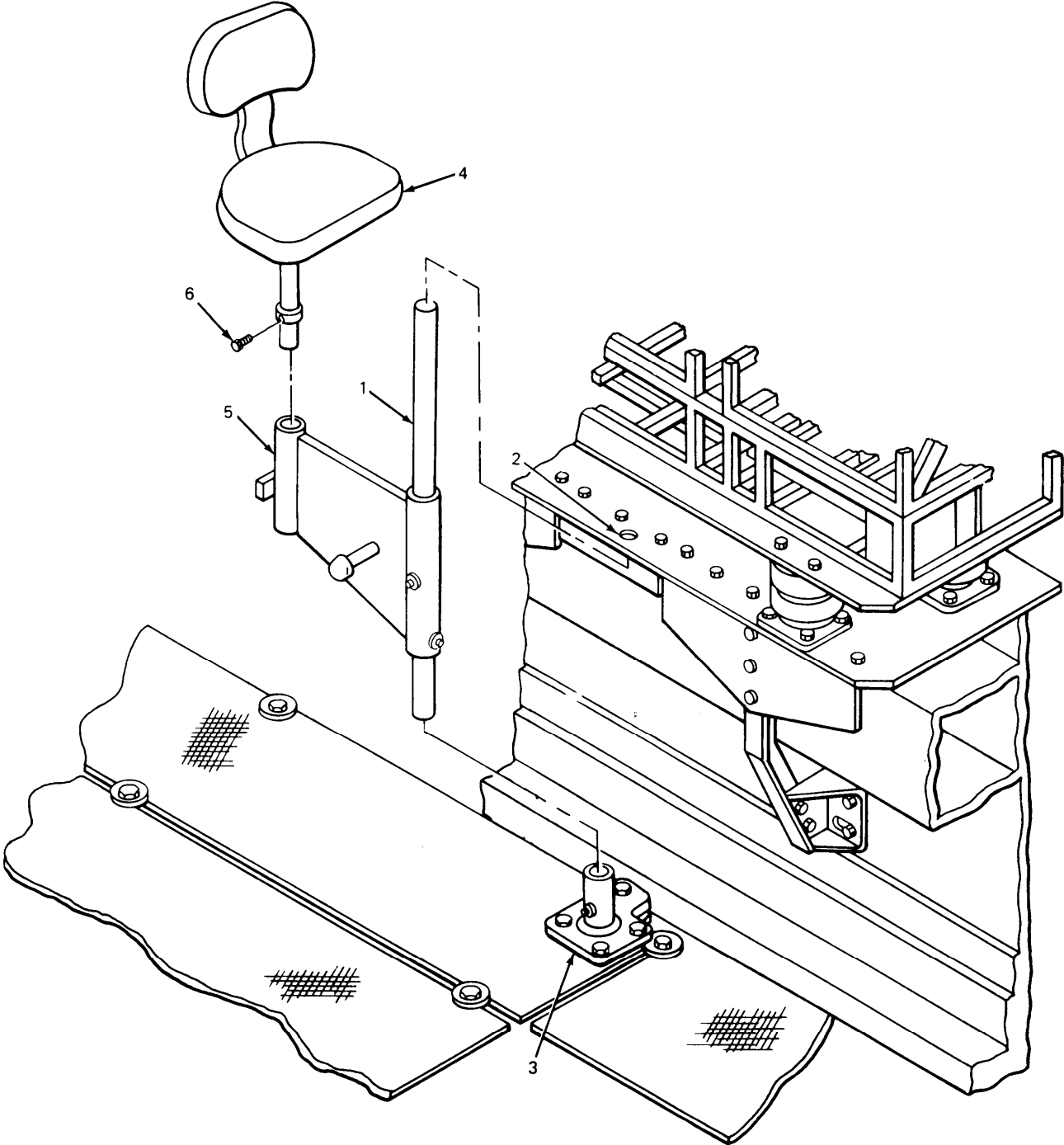

EL8KH023

**4-17. INSTALLING 4 INCH GROUND STRAPS.**

This task covers:

Installation

**INITIAL SETUP**

Tools

Personnel Required

Pliers

One mechanic

Materials/Parts

Equipment Condition

No. 10-32 brass wingnut (12 required)  
 No. 10 IT lockwasher (24 required)  
 Ground strap 4 inch (6 required)

Tacfire rack assembled. See paragraphs 4-10 thru 4-14.

LOCATION	ITEM	ACTION REMARKS
----------	------	-------------------

**NOTE**

When wingnuts are tightened, hold ground strap from turning so it will not break.

1. Upper studs on electronic equipment racks	IT lockwashers (1), ground strap (2) and wingnut (3)	Using pliers, install.
2. Lower studs on electronic equipment table	IT lockwashers (4), ground strap (2) and wingnut (5)	Using pliers, install. There are six ground straps. Steps 1 and 2 are typical for all six.
3.	Ground straps (6)	Do steps 1 and 2 for remaining five ground straps.

**NOTE**

Additional ground straps are required for properly grounding electronic equipment. Refer to TM 11-7440-251-10 and TM 11-7440-253-10-1.



4-17. INSTALLING 4 INCH GROUND STRAPS. (CONT)

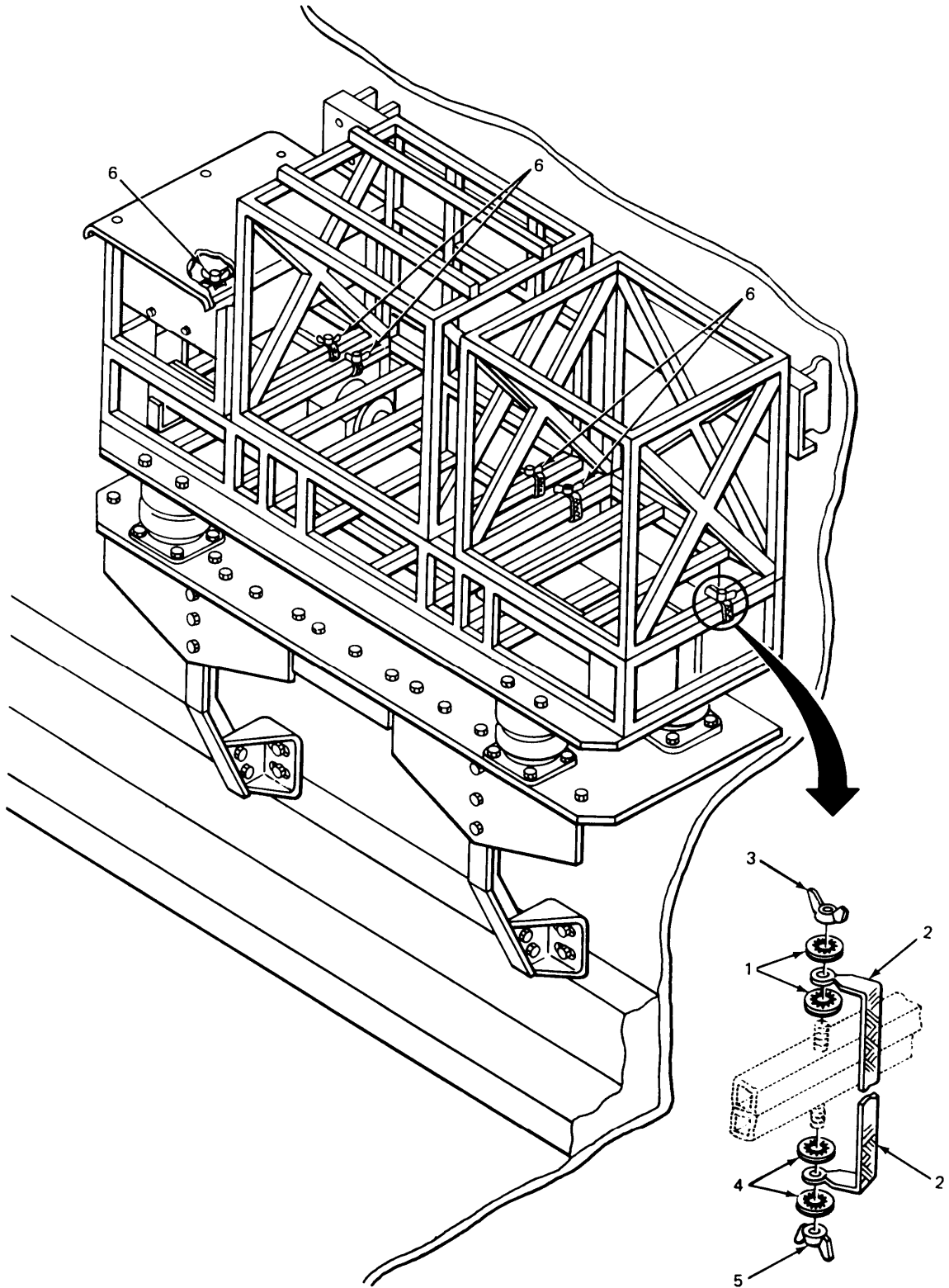

**4-18. INSTALLING ELECTRONIC LINE PRINTER SLIDING TRAY.**

This task covers:

Installation

**INITIAL SETUP**

**Tools**

9/16-inch box wrench

**Personnel Required**

One mechanic

**Materials/Parts**

ELP sliding tray  
 3/8-24 x 7/8 inch long hex head  
 screw (4 required)

**Equipment Condition**

ELP rack installed.

LOCATION	ITEM	ACTION REMARKS
1. Inside ELP rack	ELP tray (1) and ELP rack (2)	Place tray inside rack and aline holes.
2.	Screw (3)	Install, handtighten. <b>There are four screws. Step 2 is typical for all four screws.</b>
3.	Screws (4)	Do step 2 again.
	Screws (3)	Using 9/16-inch box wrench, tighten.

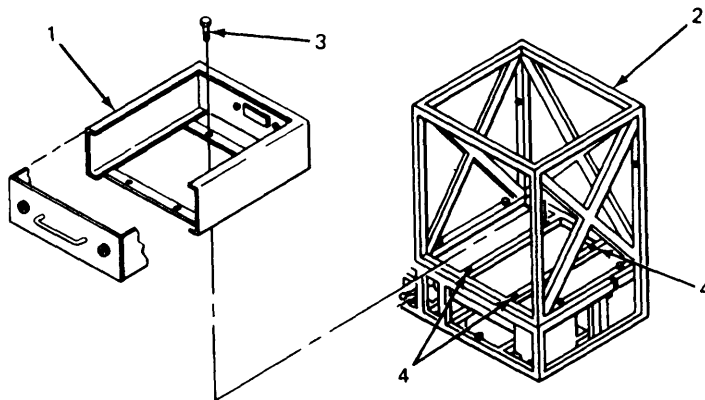

EL8KH121



**4-19. INSTALLING TACFIRE COMPONENTS.**

This task covers:

Installation

**INITIAL SETUP**

**Tools**

Flat tip screwdriver

**Personnel Required**

Two mechanics

**Materials/Parts**

Power Distribution Box  
J-3030/GSG-10(V)  
Electronic line printer  
Message entry group  
Key generator

**Equipment Condition**

Tacfire rack installed. See paragraphs 4-10 thru 4-15.

LOCATION	ITEM	ACTION REMARKS
----------	------	-------------------

**NOTE**

A helper will be needed to lift and carefully slide tacfire components into place engaging shear pins on rear of racks. This is typical for steps 1 and 2.

1. Electronic line printer rack	Electronic line printer (1)	Install.
---------------------------------	-----------------------------	----------

**NOTE**

The electronic line printer is secured to an interface mounting base which is bolted to tapped holes in electronic line printer rack. This permits electronic line printer to slide in and out of rack.

2. Message entry group rack	Message entry group (2)	Install.
-----------------------------	-------------------------	----------

4-19. INSTALLING TACFIRE COMPONENTS. (CONT)

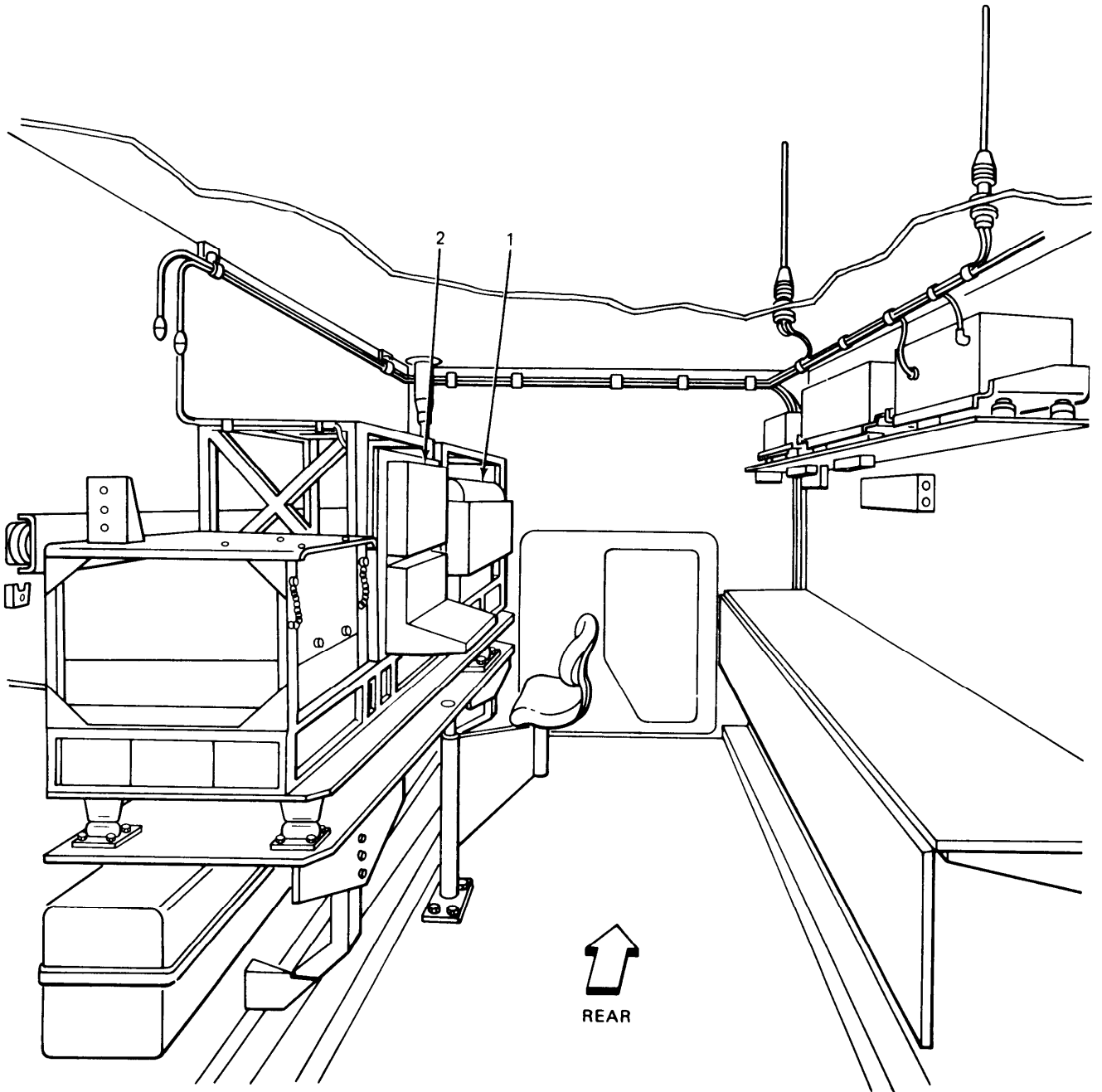

4-19. INSTALLING TACFIRE COMPONENTS. (CONT)

LOCATION	ITEM	ACTION REMARKS
3. Key generator rack	Key generator (1) and key generator rack (2)	Put key generator on top of key generator rack and aline holes.
4.	Screw (3)	Using flat tip screwdriver, install. <b>There are four screws. Step 2 is typical for all four screws.</b>
5.	Screw holes (4)	Do step 2 again.
6. Beneath storage pin on KG rack	Power distribution box J-3030 (5)	Mount and install. <b>Slide into position and secure with captive screws.</b>

**NOTE**

For completion of electronic equipment installation, cabling, connector interface bracket and ground strap connections, refer to TM 11-7440-251-10 and TM 11-7440-253-10-1.

4-19. INSTALLING TACFIRE COMPONENTS. (CONT)

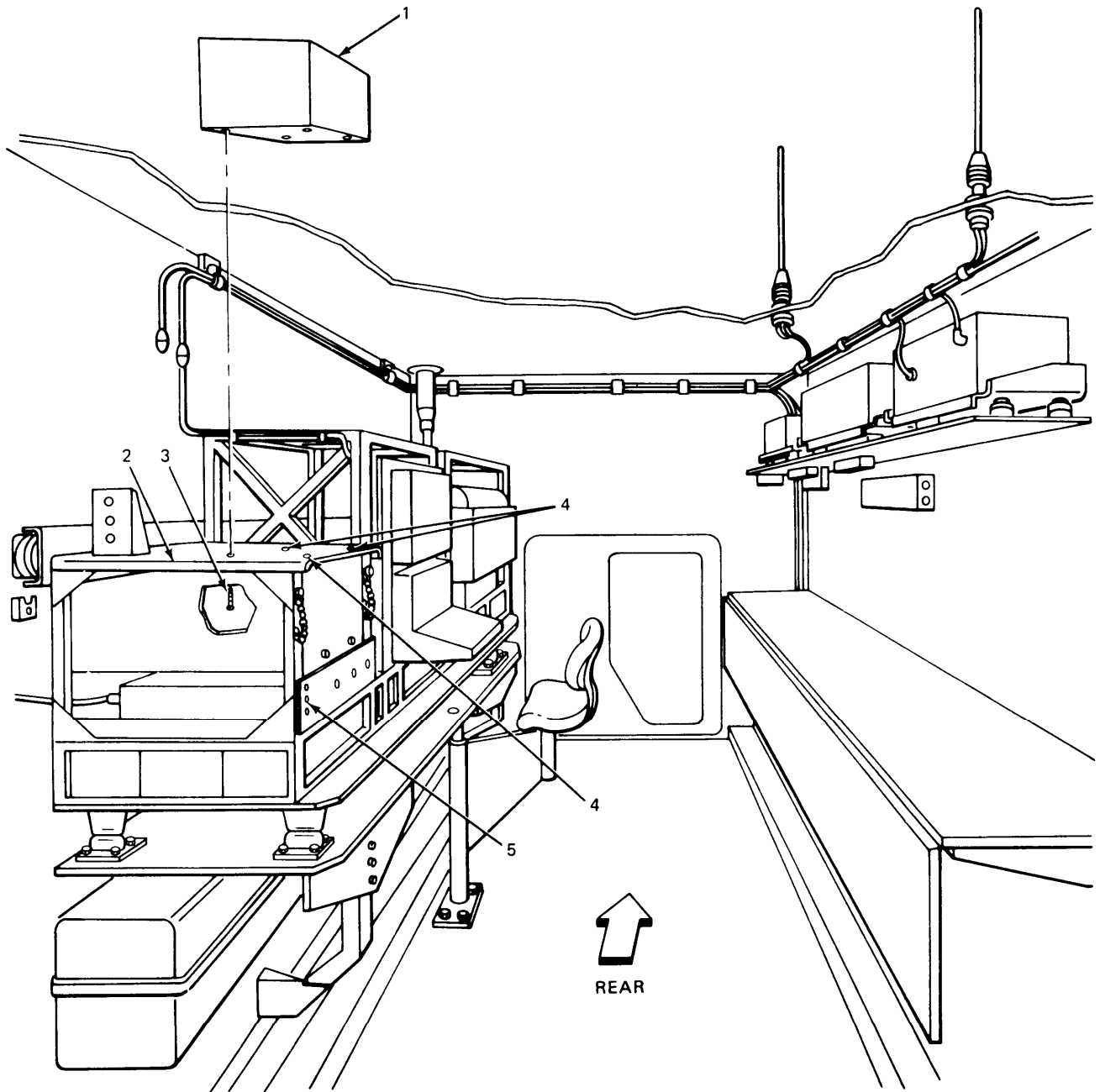

**4-20. INSTALLING 6 INCH AND 15 INCH GROUND STRAPS.**

This task covers:

Installation

**INITIAL SETUP**

**Tools**

Flat tip screwdriver,  
 9/16 inch box wrench  
 1/2 inch box wrench  
 (2 required)  
 Pliers

**Materials/parts (Cont)**

5/16 inch IET lockwasher  
 (2 required)  
 Ground strap (6 inch)  
 Ground strap (15 inch)

**Materials/parts**

3/8-16 x 1 inch long pan  
 head screw  
 3/8-16 nut  
 3/8 inch IT lockwasher (2 required)  
 5/16-24 x 3/4 inch long hex  
 head screw  
 5/16-24 nut

**Personnel Required**

One mechanic

**Equipment Condition**

Power distribution box  
 installed. See paragraph 4-19.

LOCATION	ITEM	ACTION REMARKS
1. Rear of power distribution box ground stud	Wingnut (1)	Using pliers, remove.
2.	15 inch ground strap (2), 6 inch ground strap (3), and wingnut (1)	Using pliers, install. <b>Put one end of each ground strap on stud.</b>
3. Rear of key generator rack	Screw (4), IT lockwashers (5), 6 inch ground strap (3) and nut (6)	Using flat tip screwdriver, and 9/16 inch box wrench, install.
4. Table support bracket	screw (7), IET lockwashers (8), 15 inch ground strap (2) and nut (9)	Using two 1/2 inch box wrenches, install.



4-20. INSTALLING 6 INCH AND 15 INCH GROUND STRAPS. (CONT)

LOCATION	ITEM	ACTION REMARKS
----------	------	-------------------

**NOTE**

Additional ground straps are required for properly grounding the electronic equipment. Refer to TM 11-7440-251-10 and TM 11-7440-253-10-1.

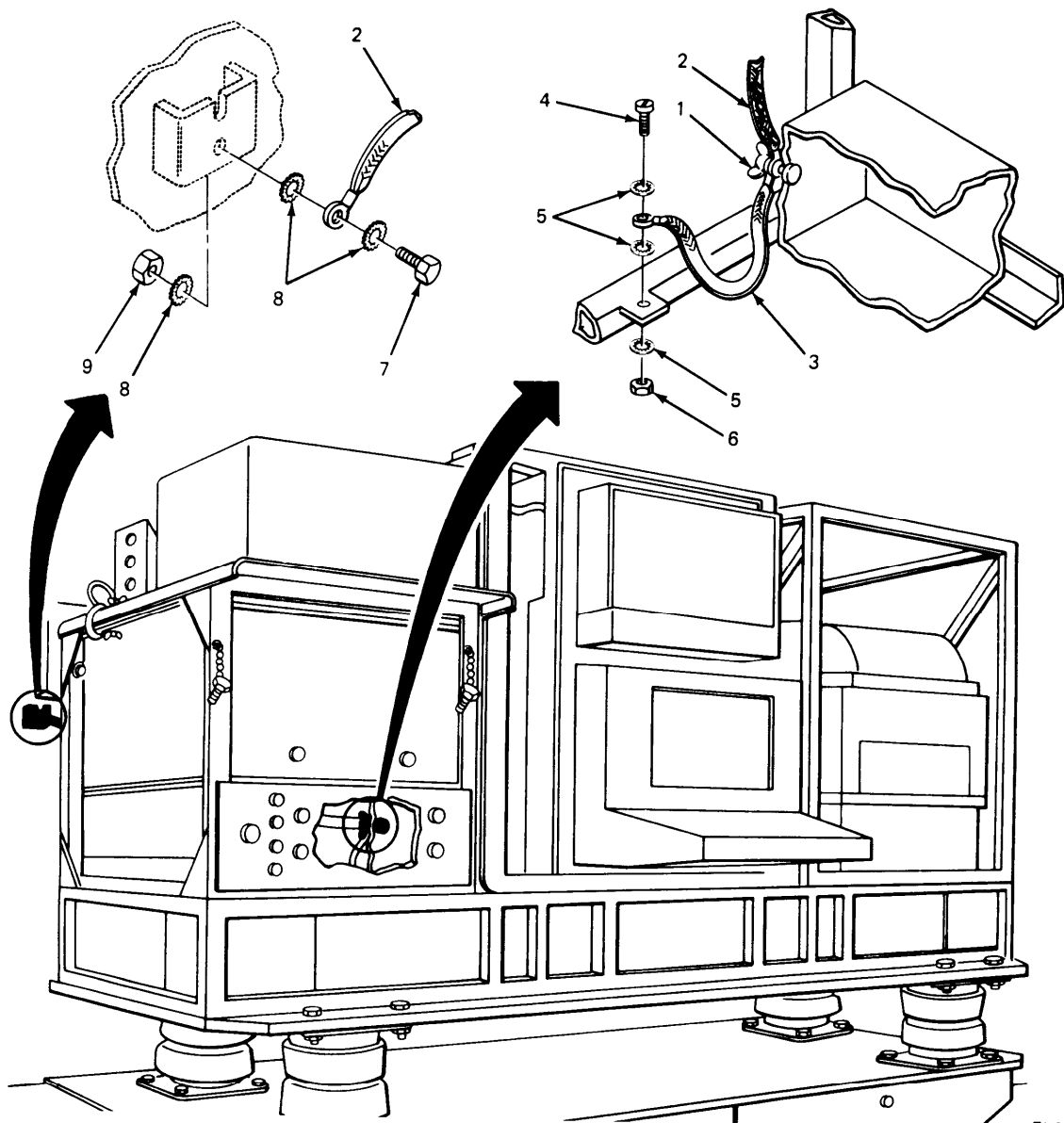

EL8KH027

**4-21. INSTALLING W280 CABLE ASSEMBLY.**

This task covers:

Installation

INITIAL SETUP

Tools

None

Personnel Required

One mechanic

Materials/Parts

Nylon strap (as required)  
 Plastic strap  
 (as required)  
 Cable assembly W280

Equipment Condition

Tacfire components installed.  
 See paragraph 4-19.

LOCATION	ITEM	ACTION REMARKS
1. Receptacle J6 on remote data terminal	Cable assembly W280 (1)	Connect. <b>Connect 90 degree elbow end.</b>
2. Message entry group rack	Cable assembly W280 (1)	Route.
3.	Nylon straps (2)	Install using nylon and plastic straps to secure cable assembly as required.

4-21. INSTALLING W280 CABLE ASSEMBLY. (CONT)

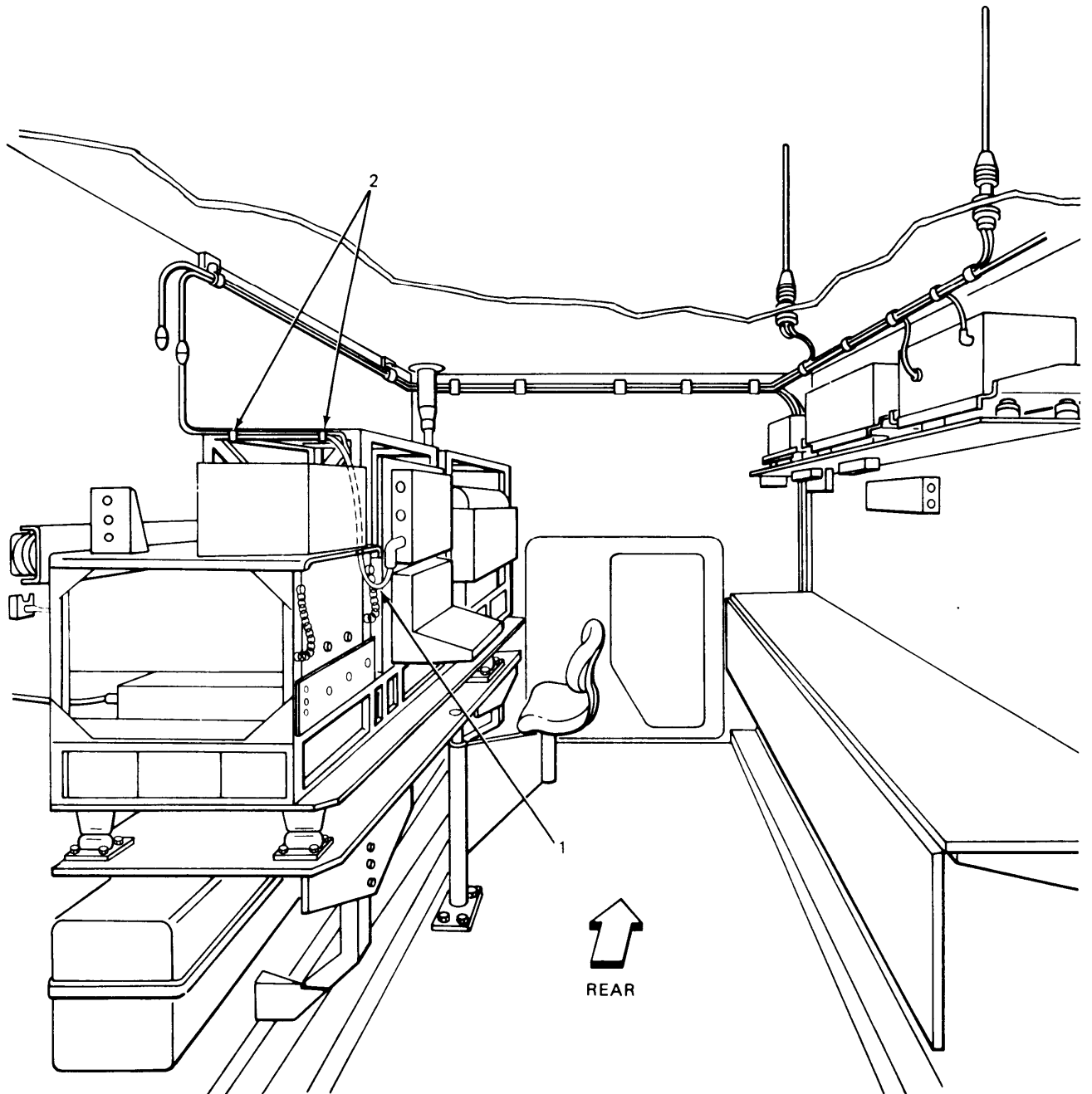

**4-22. INSTALLING CX-13088/U AND CX-13050/U CABLE ASSEMBLY.**

This task covers:

Installation

**INITIAL SETUP**

**Tools**

Flat tip screwdriver

**Materials/Parts (Cont)**

Cable Assembly CX-13088/U  
(16 feet)

**Materials/Parts**

1/4-28 x 3/4 inch long hex  
head screw (2 required)  
1/4-28 nut (2 required)  
1/4 inch IT lockwasher  
(2 required)

**Personnel Required**

One mechanic

Cable support kit  
Cable Assembly CX-13050/U  
(16 feet)

**Equipment Condition**

Tacfire components installed.  
See paragraph 4-19.

LOCATION	ITEM	ACTION REMARKS
----------	------	-------------------

**NOTE**

Use Cable Assembly CX-13050/U for single radio transmitter operation. Use Cable Assembly CX-13088/U when radio transmitters are used in retransmission mode.

1. Curbside, rear, and roadside wall	Cable Assembly CX-13050/U (1), Cable Assembly CX-13088/U (2) and nylon straps (3)	Route and secure with nylon straps. Secure to existing cables as needed.
2.	Screw (4), cable clamp (5), IT lockwasher (6) and nut (7)	Using flat tip screwdriver, install. There are two support brackets to secure cables. Step 2 is typical for both support brackets.
3.	Support bracket (8)	Do step 2 again.

4-22. INSTALLING CX-13088/U and CX-13050/U CABLE ASSEMBLY. (CONT)

LOCATION	ITEM	ACTION	REMARKS
----------	------	--------	---------

**NOTE**

For cable connections refer to SB 11-131. When Cable Assembly CX-13088/U is used, connect one end to Cable Assembly W280. Other end connects to Radio Transmitter RT-524/VRC or 5 pin on C-2299. When Cable Assembly CX-13050/U is used, connect one end to W280 and othe end to J-511 or J-509 of AM-1780 or J-22 on MT-1029.

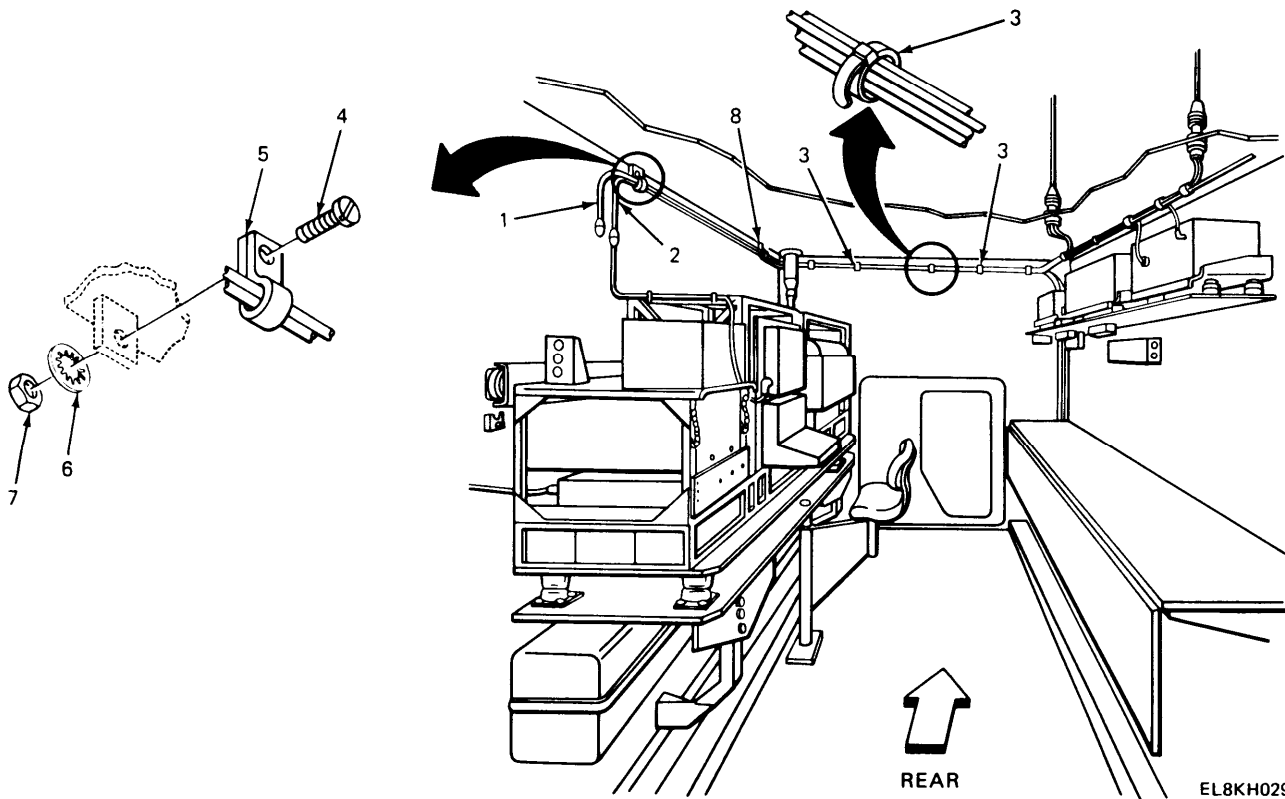

**4-23. INSTALLING 15 FOOT CABLE ASSEMBLY.**

This task covers:

Installation

**INITIAL SETUP**

**Tools**

Wire cutters  
Flat tip screwdriver

**Personnel Required**

One mechanic

**Equipment Condition**

Tacfire components installed.  
See paragraph 4-19.

**Materials/Parts**

Cable support kit  
Connector adapter  
Connector plug  
Cable assembly (15 feet)

LOCATION	ITEM	ACTION REMARKS
----------	------	-------------------

**NOTE**

Remove the two 3/8 inch terminal lugs on one end of 15 foot cable assembly. Install connector adapter and connector plug.

1. One end of 15 foot cable assembly	Terminal lugs (1)	Using wire cutters, remove.
2.	Connector adapter (2) and connector plug (3)	Using flat tip screwdriver, install.

**NOTE**

Route 15 foot cable assembly from Power Distribution Box J-3030/GSG-10(V) along curbside wall, to power receptacle located in roadside front corner of personnel compartment beneath radio shelf. Secure 15 foot cable assembly to existing wall brackets with cable support kit.

3. Curbside wall to forward wall	15 foot cable assembly (4)	Route and secure.
----------------------------------	----------------------------	-------------------

4-23. INSTALLING 15 FOOT CABLE ASSEMBLY. (CONT)

LOCATION	ITEM	ACTION REMARKS
4. Curbside wall to forward wall	15 foot cable assembly (4)	Install. <b>Use nylon straps to secure in position to existing support brackets.</b>

**NOTE**

Refer to TM 11-7440-251-10 and TM 11-7440-253-10-1 for 15 foot cable assembly connections.

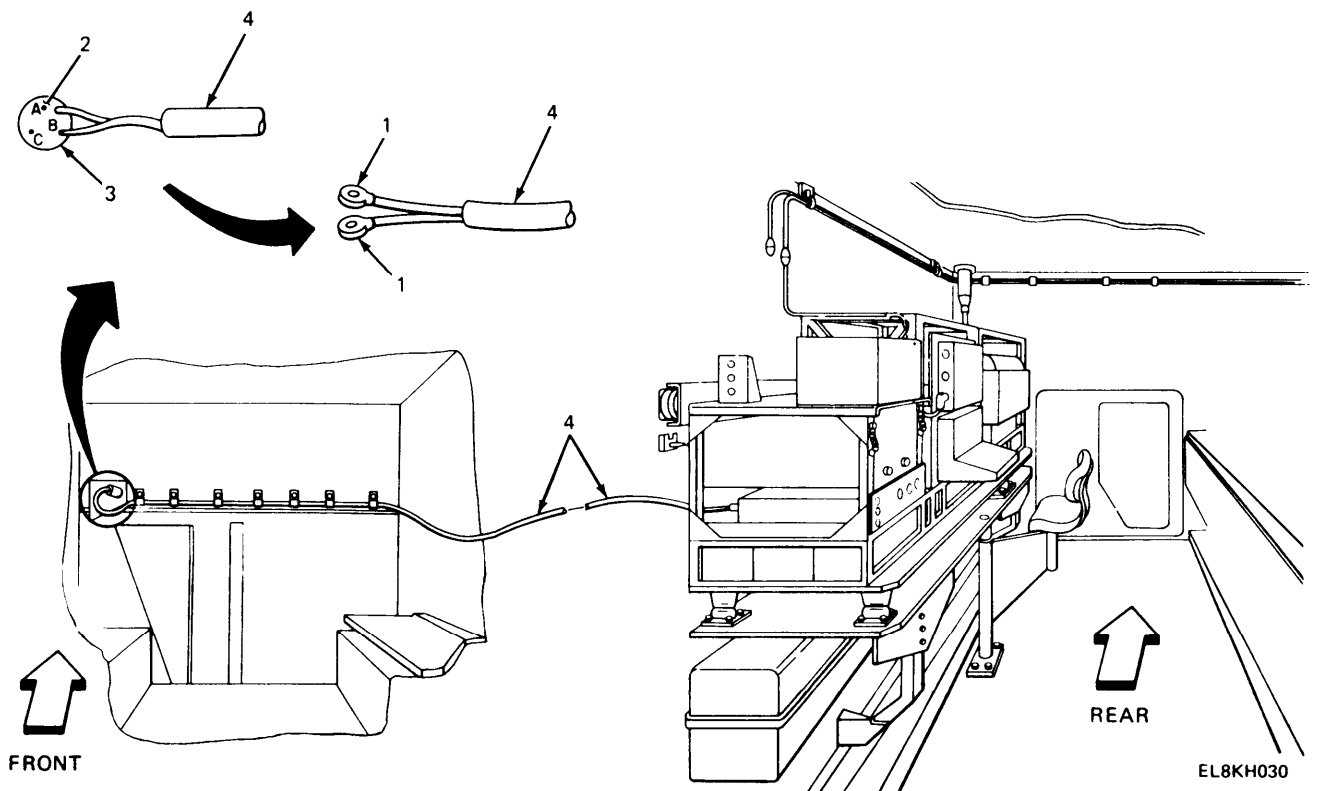

**4-24. INSTALLING SAFETY BAR.**

This task covers:

Installation

INITIAL SETUP

Tools

9/16 inch box wrench  
(2 required)

Materials/parts

Safety bar

Personnel Required

One mechanic

Equipment Condition

Mount assembly installed.  
See paragraph 4-10.

LOCATION	ITEM	ACTION REMARKS
1. Curbside, top plate assembly	Screw (1), flat washers (2) and nut (3)	Using two 9/16 inch box wrenches, remove. <b>There are four screws. Step 1 is typical for all four screws.</b>
2.	Screws (4)	Do step 1 again.
3. Curbside	Safety bar (5) and mount assembly (6)	Put safety bar on mount assembly and aline holes.
4.	Screw (1), flat washers (2) and nut (3)	Install, hand tighten. <b>There are four screws. Step 2 is typical for all four screws.</b>
5.	Screw (4)	Do step 2 again.
6.	Screw (1) and nut (3)	Using two 9/16 inch box wrenches, tighten. <b>There are four screws. Step 4 is typical for all four screws.</b>
7.		Do step 2 for remaining three screws.



4-24. INSTALLING SAFETY BAR. (CONT)

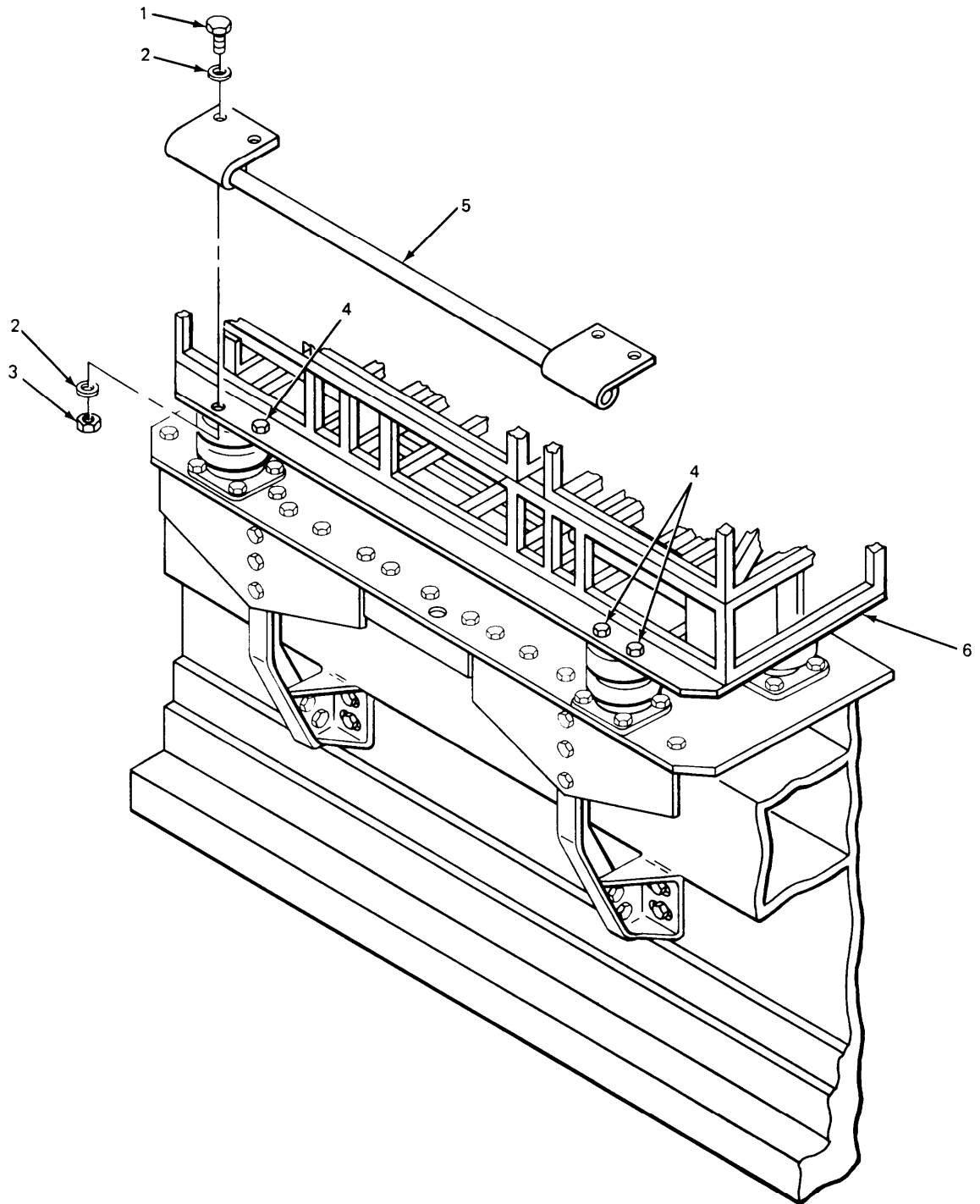

EL8KH031

**4-25. INSTALLING EXTERNAL GROUND ROD KIT.**

This task covers:

1. Preparation
2. Installation

**INITIAL SETUP**

**Tools**

- 8 lb. sledge hammer
- Hammer
- Flat tip screwdriver
- 9/16 inch box wrench
- Electric drill
- 1/8 inch drill bit
- 13/32 inch drill bit
- Center punch
- Felt tip pen
- Tape measure
- Pliers

**Materials/Parts**

- 3/8-16 x 1 1/4 inch long pan head screw
- 3/8 inch lockwasher (4 required)
- 3/8-16 nut
- 3/8-16 wingnut
- Ground strap (10 ft)
- Ground rod electrical clamp
- Ground rod (sectional)

**Personnel Required**

One mechanic

**Equipment Condition**

Vehicle non-mobile.

**LOCATION**

**ITEM**

**ACTION**

**REMARKS**

**PREPARATION**

**NOTE**

Measure a point 2 inches up from truck body, and 1/2 inch up parallel to step.

- |                              |                         |   |
|------------------------------|-------------------------|---|
| 1. Rear roadside, first step | Mark (1)                | Using felt tip pen, mark.                             |
| 2.                           | Mark (1)                | Using hammer and center punch, punch.                 |
| 3.                           | Center punched mark (1) | Using 1/8 inch drill bit and electric drill, drill.   |
| 4.                           | Drilled hole (1)        | Using 13/32 inch drill bit and electric drill, drill. |

4-25. INSTALLING EXTERNAL GROUND ROD KIT. (CONT)

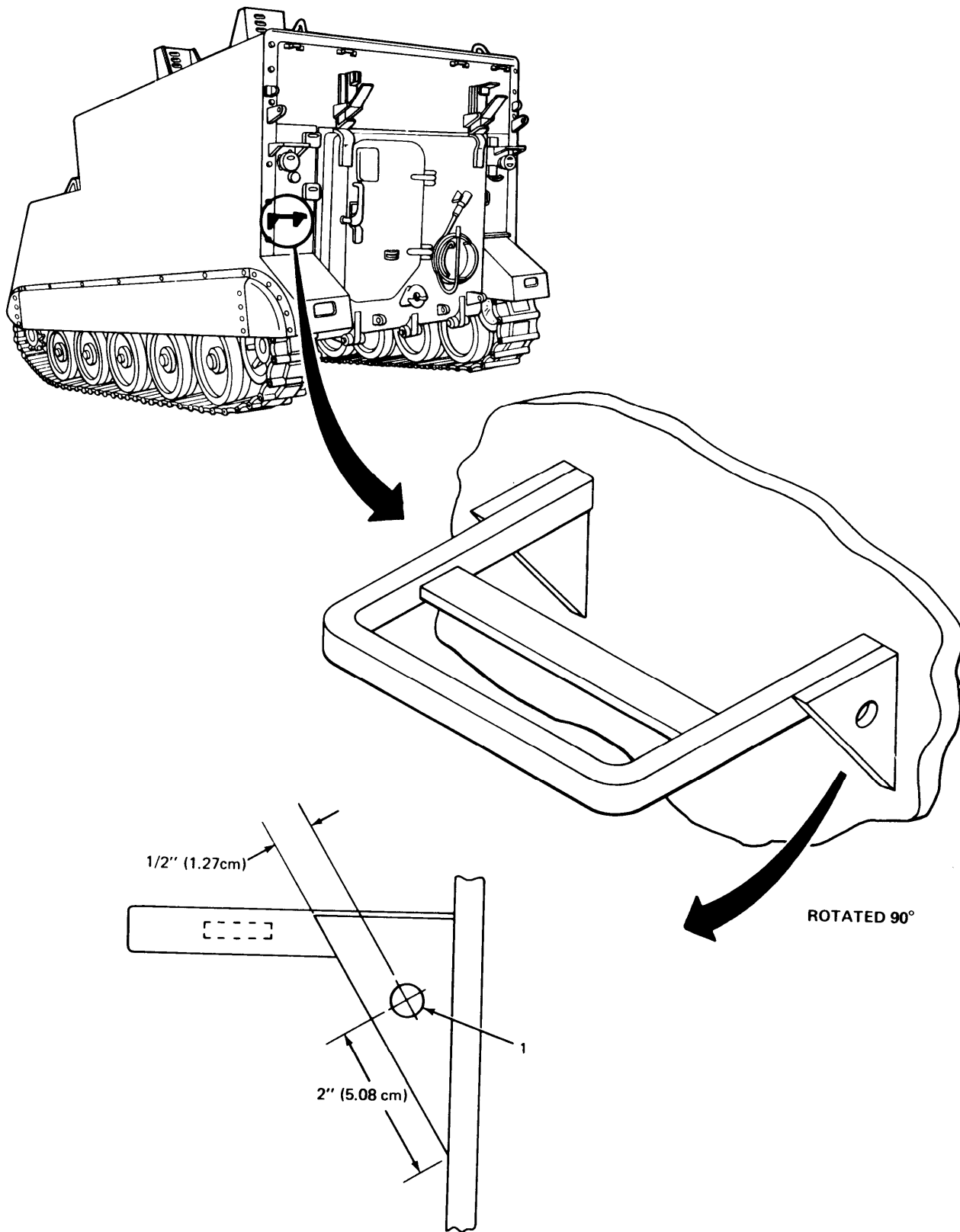

EL8KH032

4-25. INSTALLING EXTERNAL GROUND ROD KIT. (CONT)

---

LOCATION	ITEM	ACTION REMARKS
----------	------	-------------------

---

INSTALLATION

**NOTE**

The external ground rod is only used when vehicle is not moving. It is stored in a canvas bag inside of vehicle.

- |  |   |   |
|--|---|---|
| 1. Rear roadside, curbside of first step | Screw (1), lock-washers (2) and nut (3)           | Using flat tip screwdriver and 9/16 inch box wrench, install. |
| 2.                                       | Lockwashers (4), ground strap (5) and wingnut (6) | Using pliers, install.  |

**NOTE**

The ground rod comes in three sections. Using driving stud, and sledge hammer, drive one section into the ground at a time. After a section is driven into the ground, couple next section to it.

- |                     |   |                                      |
|---------------------|---|--------------------------------------|
| 3. Ground rod clamp | 10 foot ground strap (5) and ground rod strap screw (7) | Using flat tip screwdriver, install. |
| 4. Ground rod       | Ground rod clamp (8) and screws (9)                     | Using flat tip screwdriver, install. |

4-25. INSTALLING EXTERNAL GROUND ROD KIT. (CONT)

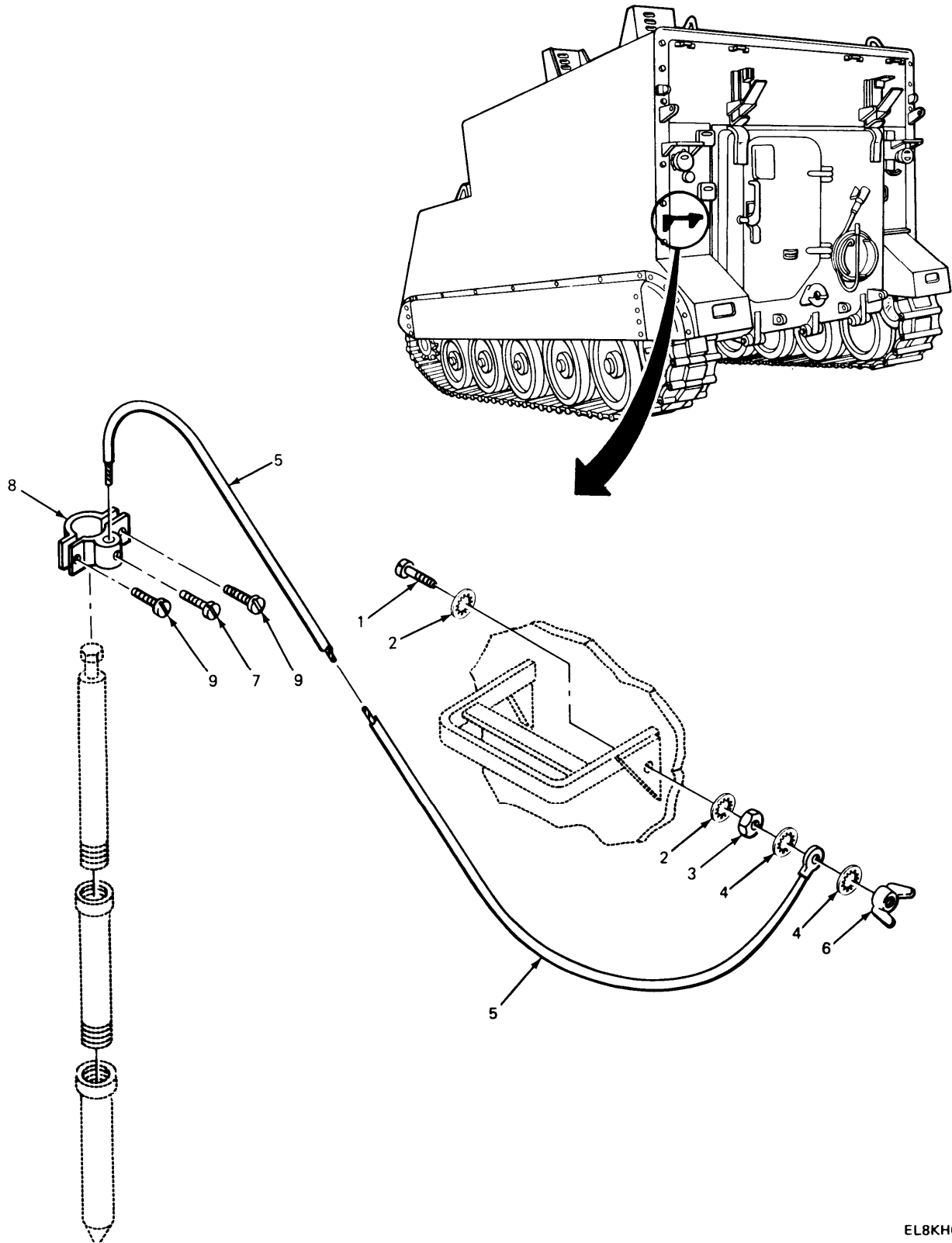

EL8KH033

#### **Section IV PREVENTIVE MAINTENANCE CHECKS AND SERVICES (PMCS)**

There are no special organizational preventive maintenance checks and services for this equipment. Routine checks like equipment inventory, broken cables, replacing damaged items, tightening loose hardware, and equipment painting are not listed in (PMCS) table. You should do these checks and services daily or at any time you see they need be done.

#### **Section V ORGANIZATIONAL TROUBLESHOOTING**

No troubleshooting procedures for the Electronics Equipment Installation Kit MK-1531( )/GSG-10(V) are given in this manual. For organizational troubleshooting procedures for the electronic equipment refer to manuals TM 11-7440-251-10 and TM 11-7440-253-10-1.

#### **Section VI MAINTENANCE PROCEDURES**

For maintenance procedures for electronic equipment used with these installation kits refer to manuals TM 11-7440-251-10 and TM 7440-253-10-1.

## Section VII REMOVAL OF ELECTRONICS EQUIPMENT INSTALLATION KIT MK-1531( )/GSG-10(V)

Subject	Para	Page
Removing Tacfire Components . . . . .	4-26	4-68
Removing Ground Straps, 4 Inch . . . . .	4-27	4-70
Removing Electronic Line Printer Sliding Tray . . . . .	4-28	4-72
Removing/Installing Electronic Line Printer Rack . . . . .	4-29	4-74
Removing/Installing Message Entry Group Rack . . . . .	4-30	4-78
Removing/Installing Key Generator Rack . . . . .	4-31	4-82
Removing/Installing Wall Mounting . . . . .	4-32	4-86
Removing/Installing Wall Mounting Tandem Cup Assemblies . . . . .	4-33	4-88
Removing Mount Assembly . . . . .	4-34	4-90
Removing/Installing Electronic Equipment Table . . . . .	4-35	4-92
Removing Top Plate Assembly . . . . .	4-36	4-94
Removing/Installing Top Plate Tandem Cup Assemblies . . . . .	4-37	4-96
Removing/Installing Bottom Plate Assembly . . . . .	4-38	4-100
Removing/Installing Bottom Plate Assembly Lower Legs . . . . .	4-39	4-104
Removing 15 Foot Cable Assembly . . . . .	4-40	4-108
Removing/Installing 6 Inch Ground Strap . . . . .	4-41	4-110
Removing/Installing 15 Inch Ground Strap . . . . .	4-42	4-112
Removing W280 Cable Assembly . . . . .	4-43	4-114
Removing CX-13050/U/CX-13088/U Cable Assembly . . . . .	4-44	4-116
Removing/Installing Seat Support Assembly . . . . .	4-45	4-118
Removing/Installing Safety Bar . . . . .	4-46	4-122
Removing External Ground Rod Kit . . . . .	4-47	4-124

**4-26. REMOVING TACFIRE COMPONENTS.**

This task covers:

Removal

INITIAL SETUP

Tools

Flat-tip screwdriver  
Cross-tip screwdriver

Materials/parts

None

Personnel Required

Two mechanics

Equipment Condition

All power off.

LOCATION	ITEM	ACTION REMARKS
1. Electronic line printer rack	Electronic line printer (1)	Remove.
2. Message entry group rack	Message entry group (2)	Remove.
3. Key generator rack	Screws (3)	Using flat-tip screwdriver, remove. <b>These are captive screws. Leave hanging on chains.</b>
4.	Screw (4)	Using cross-tip screwdriver, remove. <b>Put screw back in storage box for storage.</b>
5.	Key generator tray (5)	Lift front of tray up and pull tray out.

**NOTE**

For emergency removal do steps 3 and 5 only.

For completion of electronic equipment removal, refer to TM 11-7440-251-10 and TM 11-7440-253-10-1.

6. Tacfire racks	Tacfire components (1), (2), (5)	See paragraph 4-19 for installation.
------------------	----------------------------------	--------------------------------------



4-26. REMOVING TACFIRE COMPONENTS. (CONT)

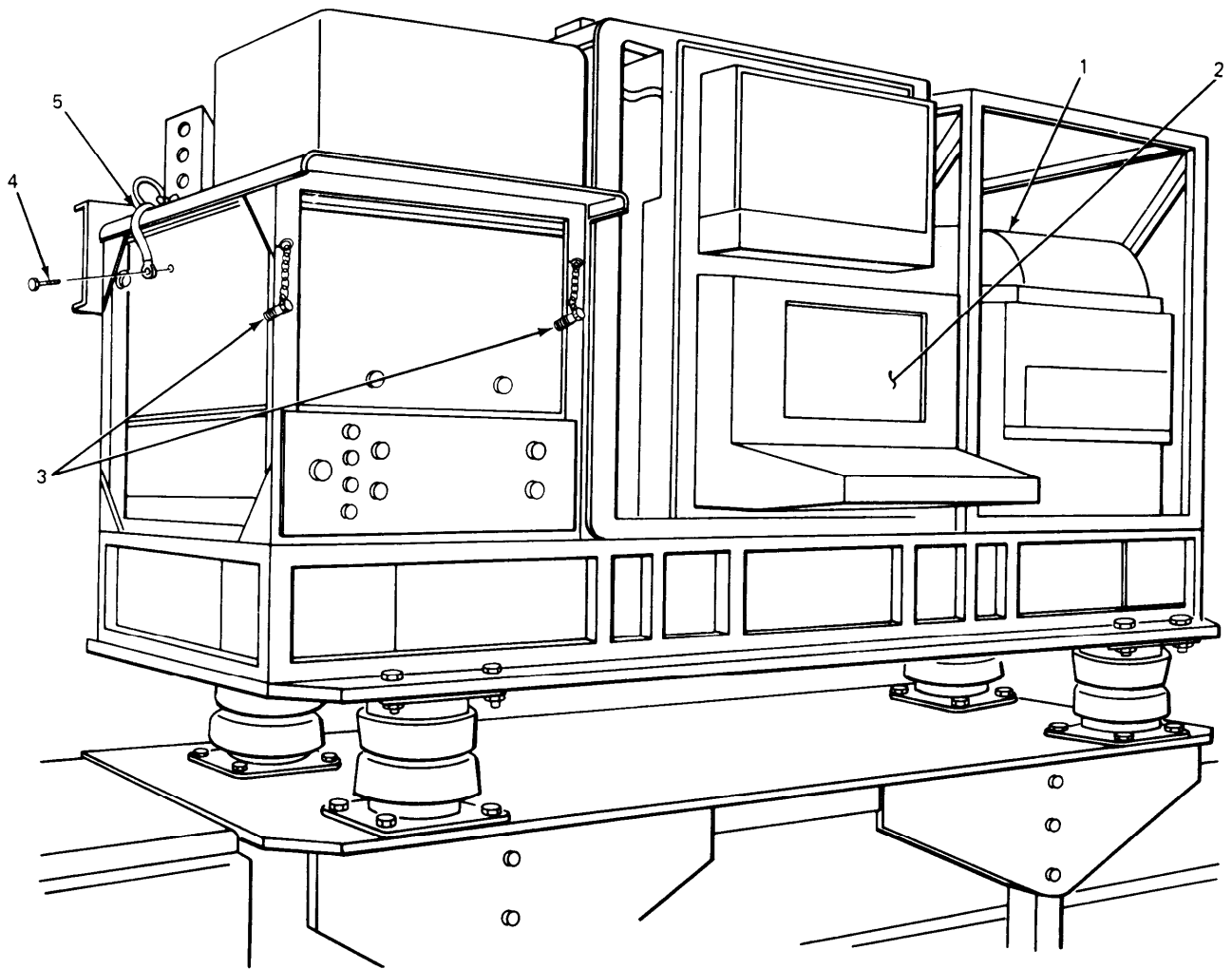

EL8KH034

**4-27. REMOVING 4 INCH GROUND STRAPS.**

This task covers:

Removal

INITIAL SETUP

Tools

Pliers

Materials/Parts

None

Personnel Required

One mechanic

Equipment Condition

Tacfire components removed. See paragraph 4-26.

	LOCATION	ITEM	ACTION REMARKS
1.	Upper stud on electronic equipment racks	Wingnut (1), IT lockwashers (2) and ground strap (3)	Using pliers, remove.
2.	Lower stud on Electronic equipment table	Wingnut (4), IT lockwashers (5) and ground strap (3)	Using pliers, remove. <b>There are six ground straps. Steps 1 and 2 are typical for all six ground straps.</b>
3.	Tacfire rack	Ground straps (6)	Do steps 1 and 2 again for each ground strap. <b>For storage, put hardware and ground straps in cloth bag, attach to rack and pack in original carton.</b>
4.		Ground straps (6)	See paragraph 4-17 for installation.

4-27. REMOVING 4 INCH GROUND STRAPS. (CONT)

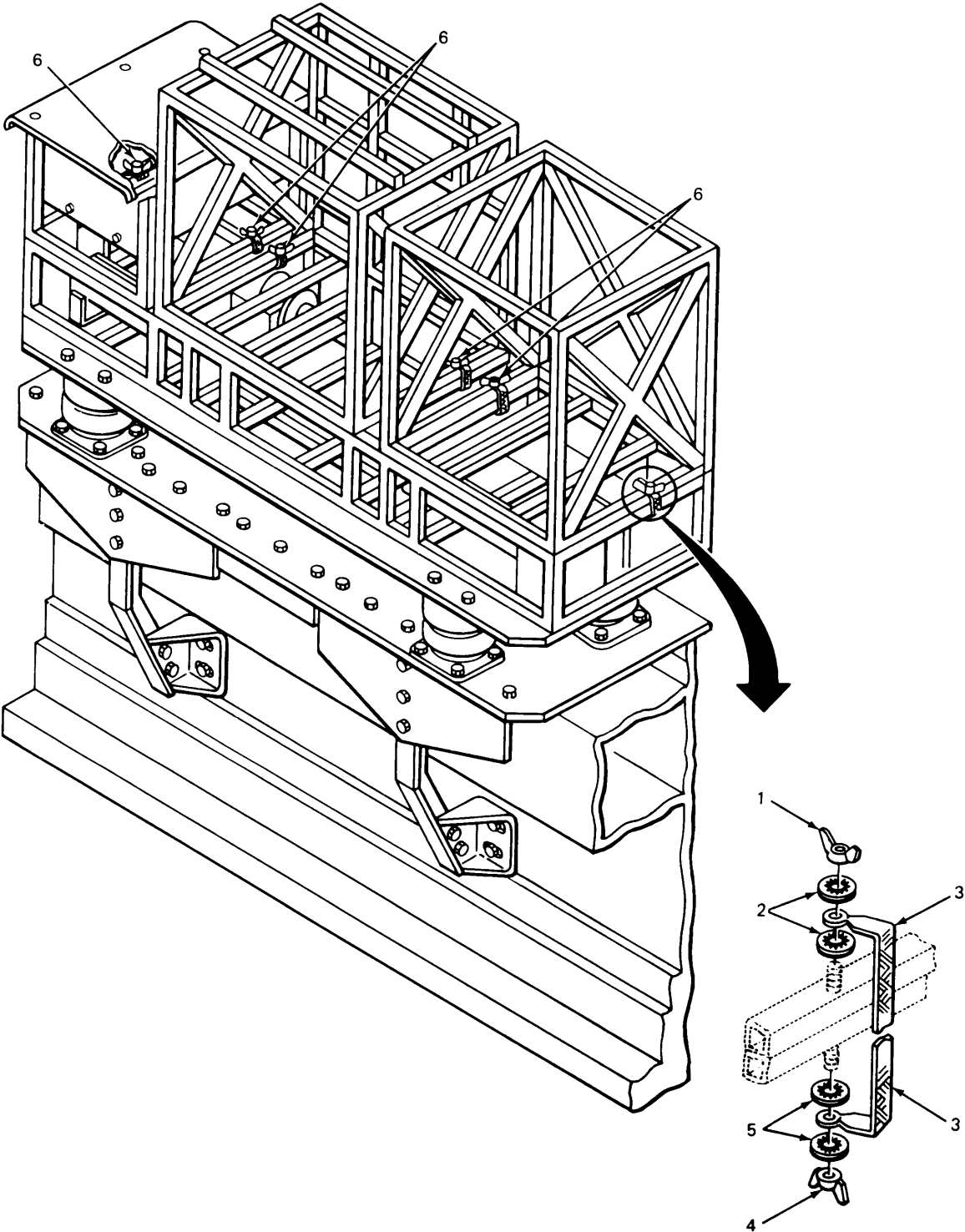

EL8KH035

**4-28. REMOVING ELECTRONIC LINE PRINTER SLIDING TRAY.**

This task covers:

Removal

**INITIAL SETUP**

**Tools**

9/16-inch box wrench

**Personnel Required**

One mechanic

**Materials/Parts**

None

**Equipment Condition**

Tacfire components removed, see paragraph 4-26.

LOCATION	ITEM	ACTION REMARKS
1. Inside ELP rack	ELP tray (1) and screw (2)	Slide tray out. Using 9/16-inch box wrench remove. <b>There are four screws. Step 1 is typical for all four screws.</b>
2.	Screws (3)	Do step 1 again.
3.	ELP tray (1)	Remove.
4.	ELP tray (1)	See paragraph 4-18 for installation.

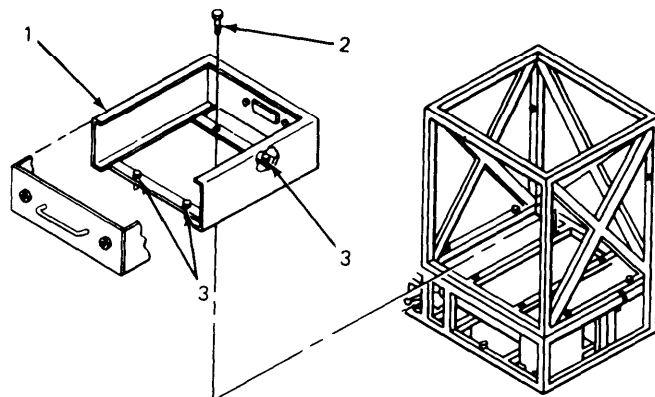



**4-29. REMOVING/INSTALLING ELECTRONIC LINE PRINTER RACK.**

This task covers:

1. Removal
2. Installation

INITIAL SETUP

Tools

1/2 inch box wrench  
(2 required)

Materials/Parts

Electronic line printer rack

Personnel Required

One mechanic

Equipment Condition

All power in vehicle off and electronic line printer removed. See paragraph 4-26. Ground straps removed. See paragraph 4-27.

LOCATION

ITEM

ACTION  
REMARKS

REMOVAL

- |  |   |  |
|--|---|--|
| 1. Lower rails of electronic line printer rack | Screw (1), flat washers (2) and nut (3) | Using two 1/2 inch box wrenches, remove.<br><b>There are four screws. Step 1 is typical for all four screws.</b>               |
| 2.   | Screws (4)                              | Do step 1 for remaining three screws.  |
| 3. Front curbside rail                         | Screw (5) and flat washer (6)           | Using 1/2 inch box wrench, remove.   |
| 4. Rear curbside rail                          | Screw (7) and flat washers (8)          | Using 1/2 inch box wrench, remove.   |
| 5. Tacfire rack                                | Electronic line printer rack (9)        | Remove.<br><b>For storage, put hardware in cloth bag, attach to electronic line printer rack and store in original carton.</b> |

4-29. REMOVING/INSTALLING ELECTRONIC LINE PRINTER RACK. (CONT)

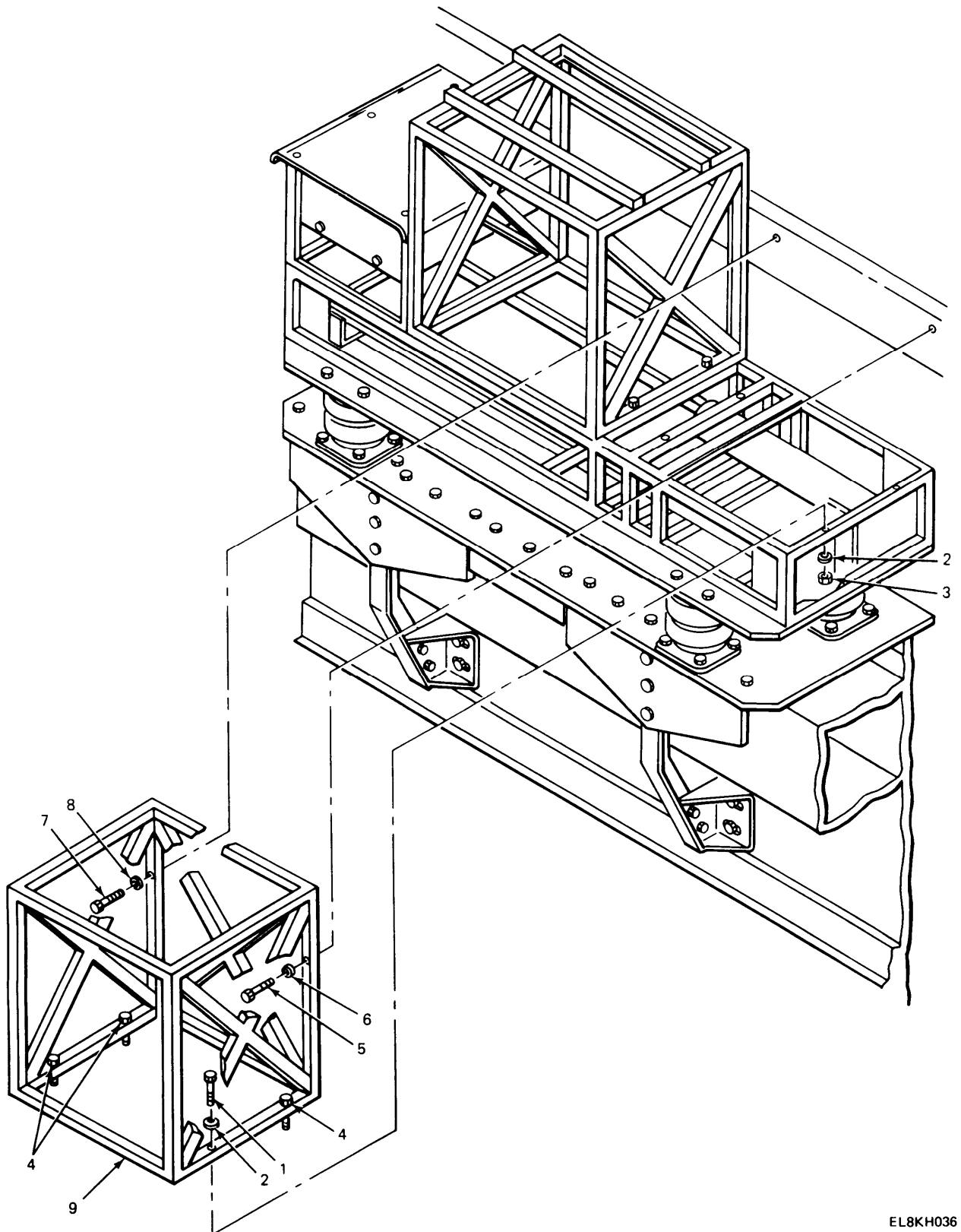

EL8KH036

4-29. REMOVING/installing ELECTRONIC LINE PRINTER RACK. (CONT)

LOCATION	ITEM	ACTION REMARKS
INSTALLATION		
1. Curbside rear of electronic equipment table	Electronic line printer rack (1) and electronic equipment table (2)	Put electronic line printer rack on electronic equipment table and align holes.
2. Lower rails of electronic line printer rack	Screw (3), flat washers (4) and nut (5)	Install, hand tighten. <b>There are four screws. Step 2 is typical for all four screws.</b>
3.	Screw holes (6)	Do step 2 again.
4. Front curbside rails	Screw (7) and flat washer (8)	Install, hand tighten.
5. Rear curbside rails	Screw (9) and flat washer (10)	Install, hand tighten.
6. Lower rails of electronic line printer rack	Screw (3) and nut (5)	Using two 1/2 inch box wrenches, tighten. <b>There are four screws. Step 6 is typical for all four screws.</b>
7.		Do step 6 for remaining three screws.
8. Front curbside rail	Screw (7)	Using 1/2 inch box wrench, tighten.
9. Rear curbside rail	Screw (9)	Using 1/2 inch box wrench, tighten.

**NOTE**

See paragraph 4-17 for installation of 4 inch ground straps.  
See paragraph 4-19 for installation of electronic line printer.



4.29. REMOVING/INSTALLING ELECTRONIC LINE PRINTER RACK. (CONT)

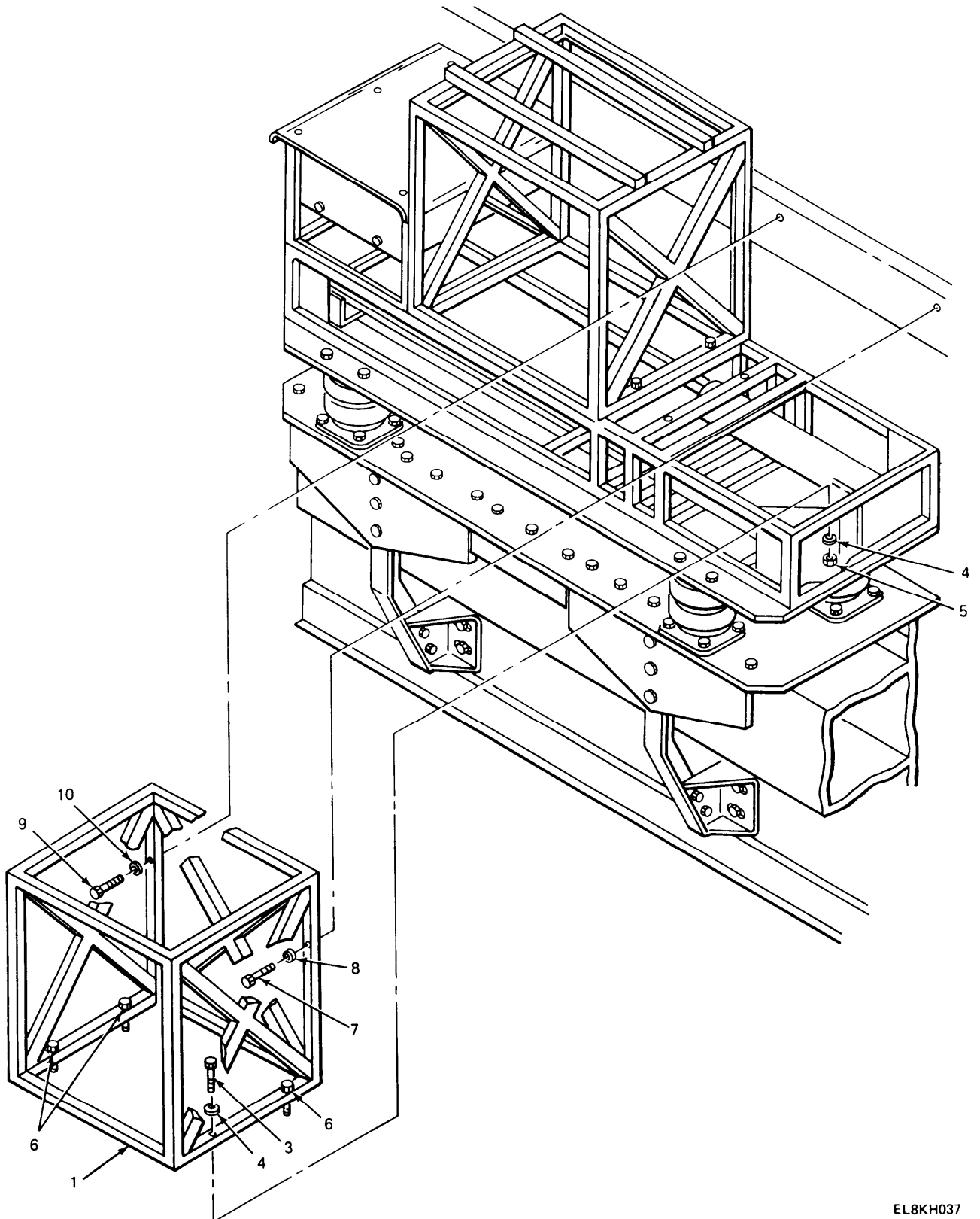

EL8KH037

**4-30. REMOVING/INSTALLING MESSAGE ENTRY GROUP RACK.**

This task covers:

1. Removal
2. Installation

**INITIAL SETUP**

Tools

1/2 inch box wrench  
(2 required)

Materials/parts

Message entry group rack

Personnel Required

One mechanic

Equipment Condition

All power in vehicle off.  
Message entry group and 4 inch  
ground straps removed. See  
paragraphs 4-30 and 4-27.

LOCATION	ITEM	ACTION REMARKS
<b>REMOVAL</b>		
1. Lower rails of message entry group rack	Screw (1), flat washers (2) and nut (3)	Using two 1/2 inch box wrenches, remove. <b>There are four screws. Step 1 is typical for all four screws.</b>
2.	Screws (4)	Do step 1 for remaining three screws.
3. Front curbside rail	Screw (5) and flat washer (6)	Using 1/2 inch box wrench, remove.
4. Rear curbside rail	Screw (7) and flat washer (8)	Using 1/2 inch box wrench, remove.
5. Tacfire rack	Message entry group rack (9)	Remove. <b>For storage, put hardware in cloth bag, attach to message entry group rack and store in original carton.</b>

4-30. REMOVING/INSTALLING MESSAGE ENTRY GROUP RACK. (CONT)

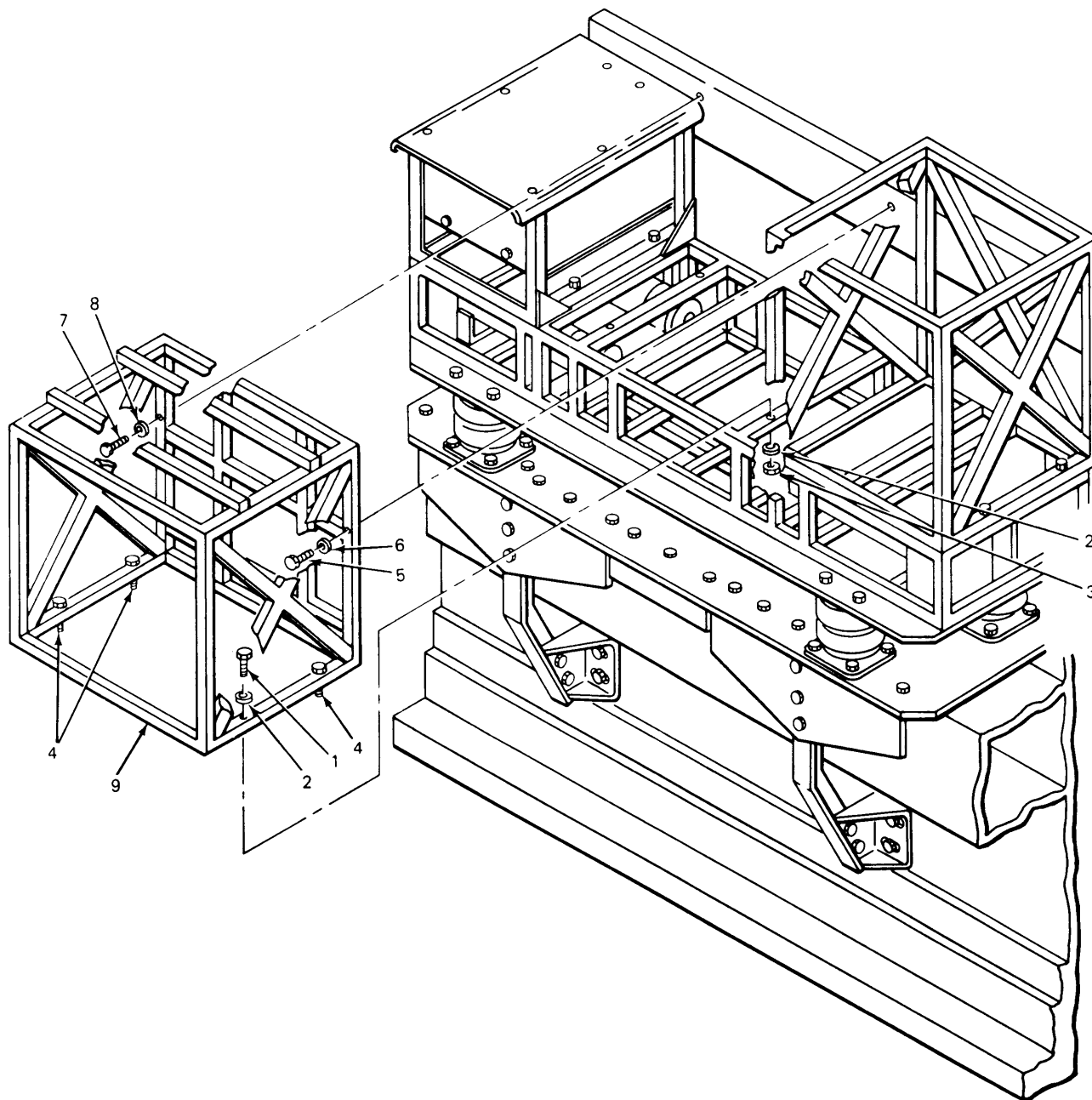

EL8KH038

4-30. REMOVING/INSTALLING MESSAGE ENTRY GROUP RACK. (CONT)

LOCATION	ITEM	ACTION REMARKS
INSTALLATION		
1. Center position on electronic equipment table	Message entry group rack (1), and electronic equipment table (2)	Put message entry group rack on electronic equipment table and aline holes.
2. Lower rails on message entry group rack	Screw (3), flat washers (4) and nut (5)	Install hand tighten. <b>There are four screws. Step 2 is typical for all four screws.</b>
3.	Screw holes (6)	Do step 2 for remaining three screws.
4. Front curbside rail	Screw (7) and flat washer (8)	Install, hand tighten.
5. Rear curbside rail	Screw (9) and flat washer (10)	Install, hand tighten.
6. Lower rails on message entry group rack	Screw (3) and nut (5)	Using two 1/2 inch box wrenches, tighten. <b>There are four screws. Step 6 is typical for all four screws.</b>
7.		Do step 6 for remaining three screws.
8. Front curbside rail	Screw (7)	Using 1/2 inch box wrench, tighten.
9. Rear curbside rail	Screw (9)	Using 1/2 inch box wrench, tighten.

**NOTE**

See paragraph 4-27 for installation of 4 inch ground straps.  
See paragraph 4-30 for installation of message entry group rack.

4-30. REMOVING/INSTALLING MESSAGE ENTRY GROUP RACK. (CONT)

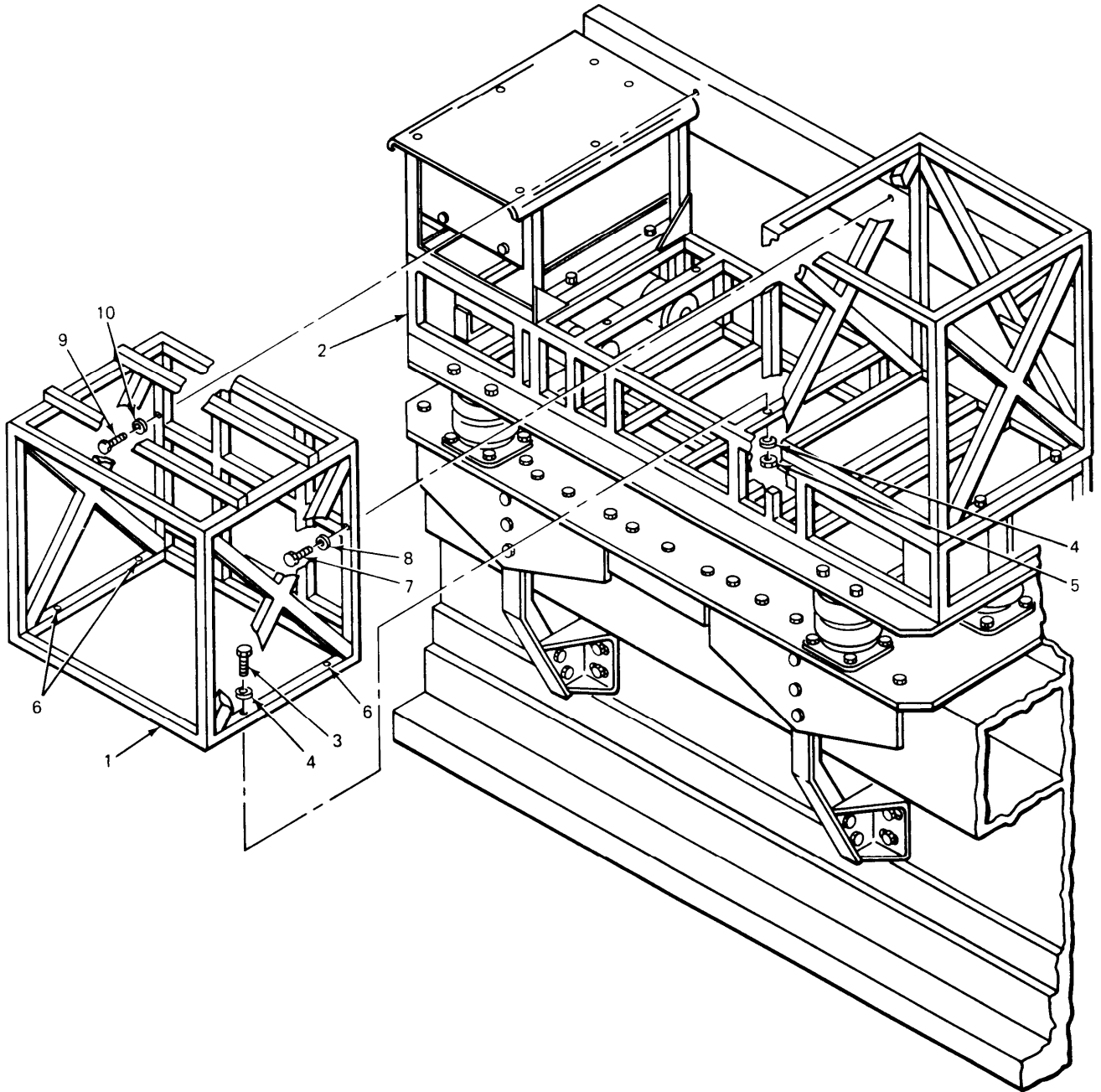

EL8KH039

**4-31. REMOVING/INSTALLING KEY GENERATOR RACK.**

This task covers:

1. Removal
2. Installation

**INITIAL SETUP**

**Tools**

Flat tip screwdriver  
 1/2 inch box wrench  
 (2 required)  
 9/16 inch wrench

**Personnel Required**

One mechanic

**Equipment Condition**

All power in vehicle off.

**Materials/Parts**

Key generator rack

LOCATION	ITEM	ACTION REMARKS
1. Rear of power distribution box	Wingnut (1), 6 inch ground strap (2) and 15 inch ground strap (3)	Using pliers, remove.
2. Key Generator rack	Screw (4), IT lockwashers (5), nut (6) and 6 inch ground strap (2)	Using flat tip screwdriver and 9/16 inch box wrench, remove.

**NOTE**

See paragraph 4-26 for removal of key generator and power distribution box. See paragraph 4-27 for removal of 4 inch ground straps.

4-31. REMOVING/INSTALLING KEY GENERATOR RACK. (CONT)

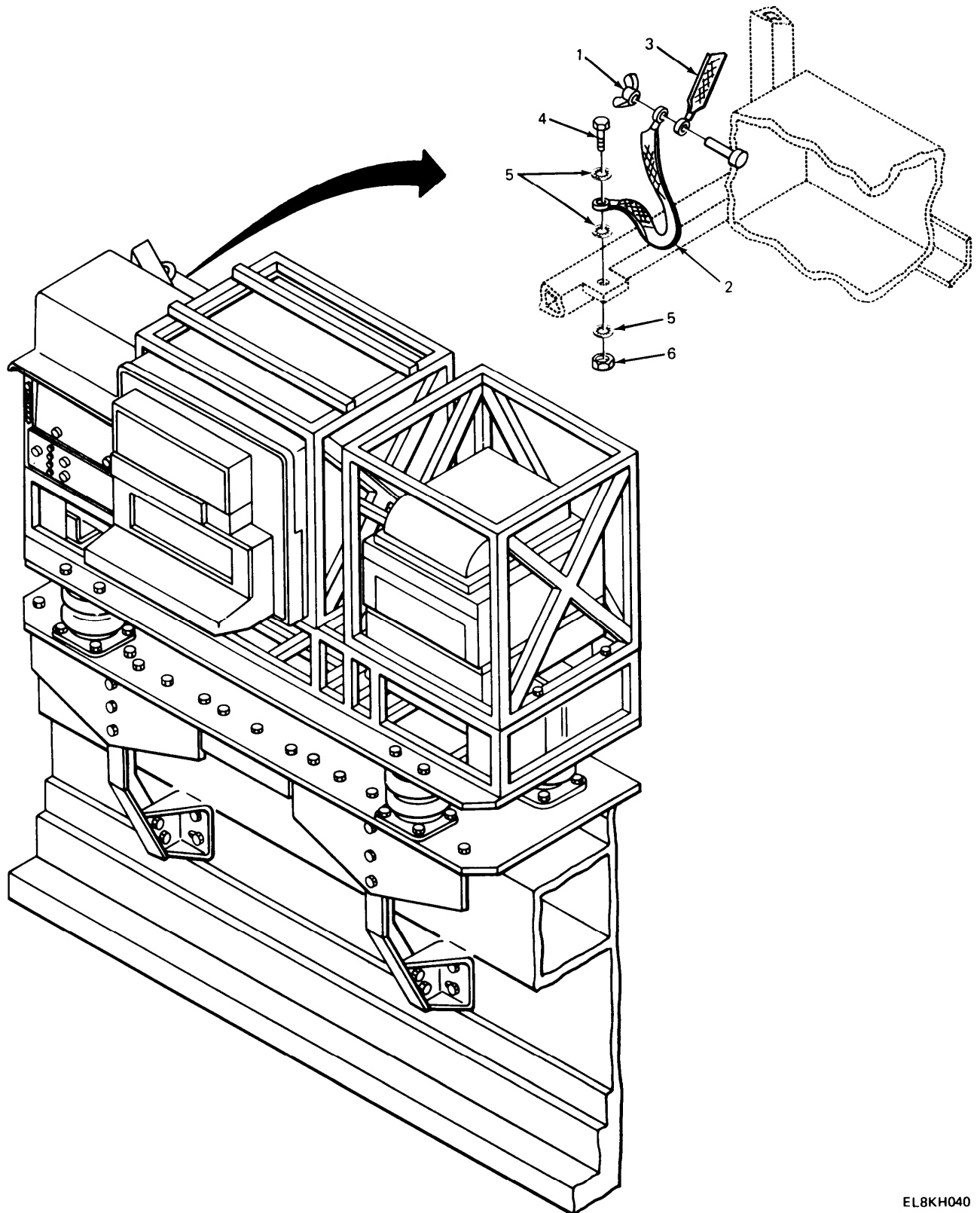

EL8KH040

4-31. REMOVING/INSTALLING KEY GENERATOR RACK. (CONT)

LOCATION	ITEM	ACTION REMARKS
REMOVAL (CONT)		
3. Front curbside of electronic equipment table	Screw (1), flat washers (2) and nut (3)	Using two 1/2 inch box wrenches, remove. <b>There are four screws. Step 1 is typical for all four screws.</b>
4.	Screws (4)	Do step 3 for remaining three screws.
5. Front curbside rail	Screw (5) and flat washer (6)	Using 1/2 inch box wrench, remove.
6. Rear curbside rail	Screw (7) and flat washer (8)	Using 1/2 inch box wrench, remove.
7. Tacfire rack	Key generator rack (9)	Remove. <b>For storage, put hardware in cloth bag, attach to key generator rack and store in original carton.</b>
INSTALLATION		
1. Tacfire rack	Key generator rack (9)	See paragraph 4-15 for installation.
<b>NOTE</b>		
See paragraph 4-17 for installation of 4 inch ground strap. See paragraph 4-19 for installation of key generator and power distribution box.		
2. Rear of power distribution box	15 inch ground strap (10), 6 inch ground strap (11) and wing-nut (12)	Using pliers, install.
3. Key Generator rack	Screw (13), IT lockwashers (14), 6 inch ground strap (11) and nut (15)	Using flat tip screwdriver and 9/16 inch box wrench, install.



4-31. REMOVING/INSTALLING KEY GENERATOR RACK. (CONT)

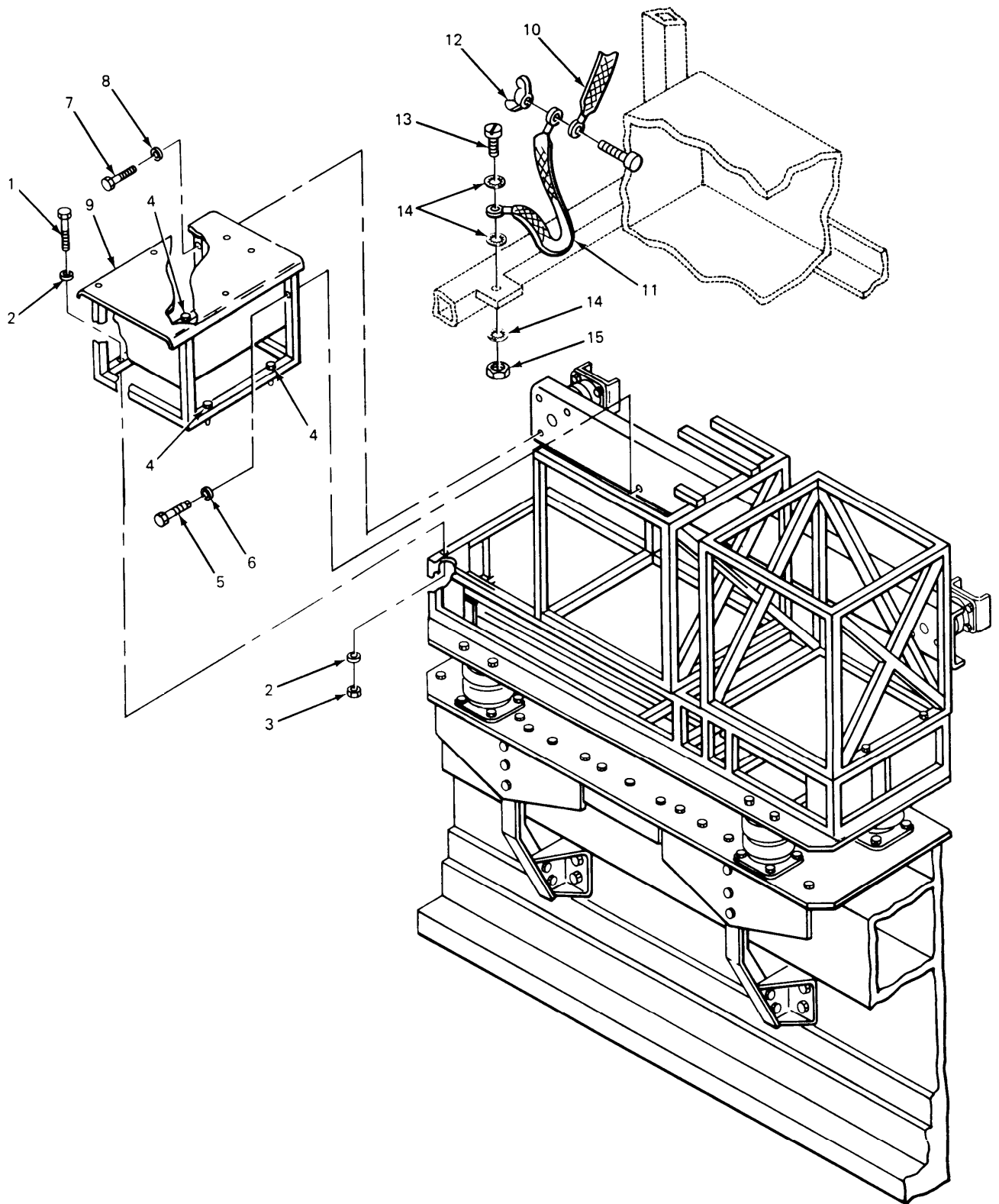

EL8KH041

**4-32. REMOVING/INSTALLATION WALL MOUNTING.**

This task covers:

1. Removal
2. Installation

**INITIAL SETUP**

Tools

Flat tip screwdriver

Materials/Parts

Wall mounting

Personnel Required

One mechanic

Equipment Condition

Tacfire components removed. See paragraph 4-26.4 inch ground straps removed. See paragraph 4-27. Electronic equipment racks removed. See paragraphs 4-29, 4-30, 4-31.

LOCATION	ITEM	ACTION REMARKS
<b>REMOVAL</b>		
1. Wall mounting	Screw (1)	Using flat tip screwdriver, remove. <b>There are four screws per tandem cup. Step 1 is typical for all four screws.</b>
2.	Screw holes (2)	Do step 1 again.
3.	Tandem cup assembly (3)	Do steps 1 and 2 again.
4. Tandem cups	Wall mounting (4)	Remove. <b>For storage, put hardware in cloth bag, attach to wall mounting and store in original carton.</b>
<b>INSTALLATION</b>		
1. Curbside wall	Wall mounting (4) and tandem cup assembly (3)	Put wall mounting on tandem cup assembly and aline holes.

4-32. REMOVING/INSTALLING WALL MOUNTING. (CONT)

LOCATION	ITEM	ACTION	REMARKS
INSTALLATION (CONT)			
2. Curbside wall	Screw (1)	Using flat tip screwdriver, install.	<b>There are four screws per tandem cup assembly. Step 1 is typical for all four screws.</b>
3.	Screws (2)	Do step 1 for remaining three screws.	
4.	Tandem cup assembly (3)	Do step 1 and 2 again.	

**NOTE**

See paragraphs 4-29, 4-30, 4-31 for installation of electronic equipment racks.

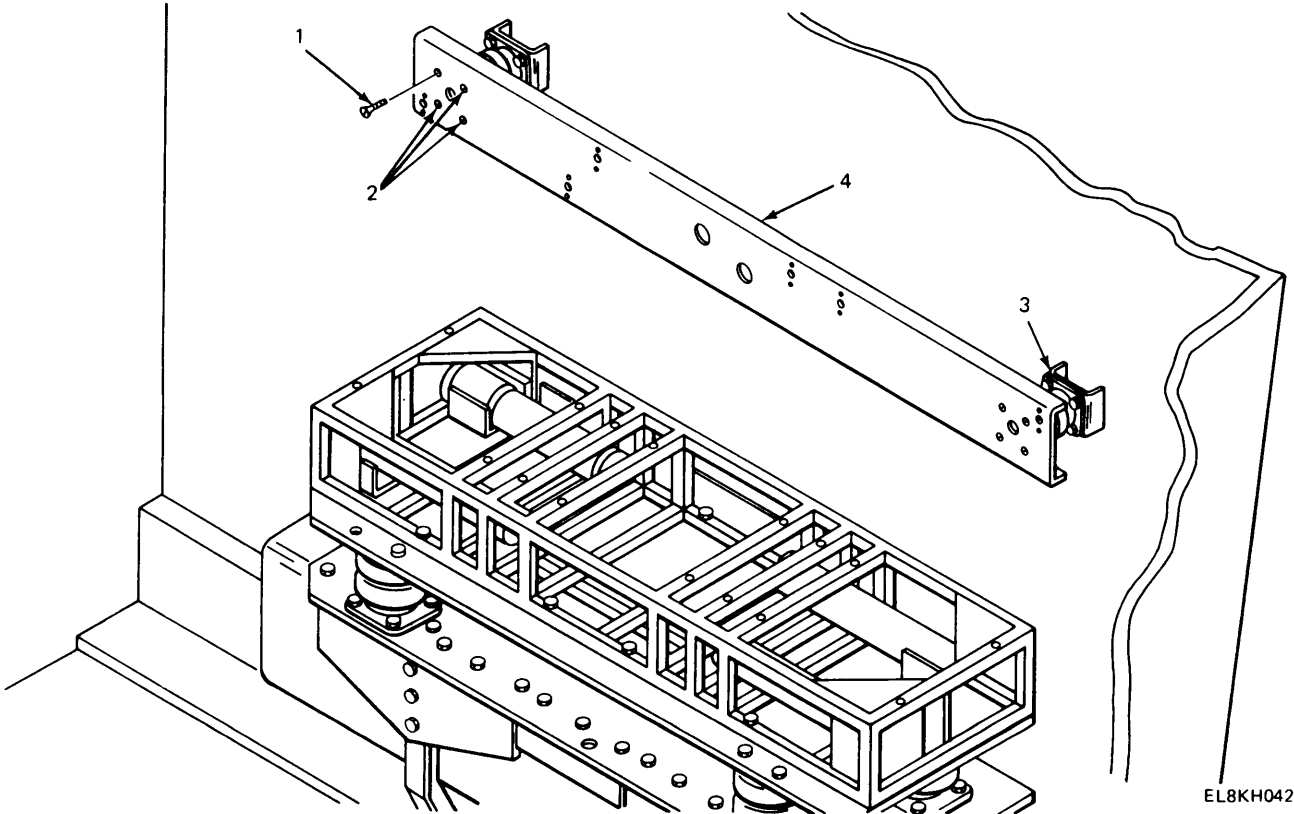

**4-33. REMOVING/INSTALLING WALL MOUNTING TANDEM CUP ASSEMBLIES.**

This task covers:

1. Removal
2. Installation

INITIAL SETUP

Tools

1/2 inch box wrench

Personnel Required

One mechanic

Materials/Parts

Tandem cup assembly

Equipment Condition

Wall mounting removed. See paragraph 4-32.

LOCATION	ITEM	ACTION REMARKS
----------	------	-------------------

REMOVAL

1. Curbside wall	Screw (1)	Using 1/2 inch box wrench, remove. <b>There are four screws. Step 1 is typical for all four screws.</b>
2.	Screws (2)	Do step 1 for remaining three screws.
3.	Tandem cup assembly (3)	Remove.
4.	Tandem cup assembly (4)	Do steps 1 thru 3 again. <b>For storage, put hardware in cloth bag, attach to tandem cup assembly and store in original carton.</b>

INSTALLATION

1. Curbside wall	Tandem cup assembly (3) and spacer assembly (5)	Put tandem cup assembly over spacer assembly and aline holes.
2.	Screw (1)	Using 1/2 inch box wrench, install. <b>There are four screws. Step 2 is typical for all four screws.</b>
3.	Screws (2)	Do step 2 for remaining three screws.

4-33. REMOVING/INSTALLING WALL MOUNTING TANDEM CUP ASSEMBLY. (CONT)

LOCATION	ITEM	ACTION REMARKS
----------	------	-------------------

INSTALLATION (CONT)

- |    |                         |                          |
|----|-------------------------|--------------------------|
| 4. | Tandem cup assembly (4) | Do steps 1 thru 3 again. |
|----|-------------------------|--------------------------|

**NOTE**

See paragraph 4-32 for installation of wall mounting.

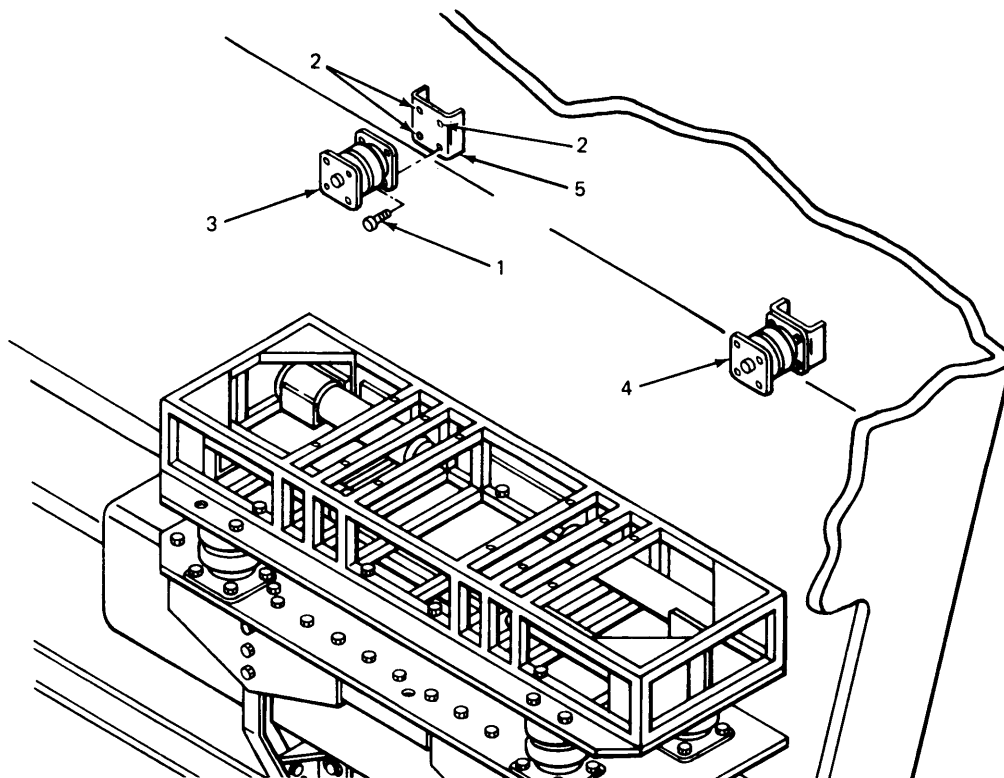

EL8KH043

**4-34. REMOVING MOUNT ASSEMBLY.**

This task covers:

Removal

**INITIAL SETUP**

Tools

9/16 inch box wrench  
3/4 inch box wrench

Materials/parts

Mount assembly

Personnel Required

Two mechanics

Equipment Condition

Electronic equipment racks removed.  
See paragraphs 4-29, 4-30, 4-31.

LOCATION

ITEM

ACTION

REMARKS

**WARNING**

The mount assembly requires two mechanics to lift and remove.

- |  |   |   |
|--|---|---|
| 1. Curbside support brackets           | Screw (1), flat washer (2), spring lockwasher (3) and shims (4) | Using 9/16 inch box wrench, remove.<br><b>There are three screws. Step 1 is typical for all three screws.</b> |
| 2.                                     | Screws (5)  | Do step 1 for remaining screws.   |
| 3. Lower curbside wall under fuel tank | Screw (6), spring lockwasher (7) and flat washer (8)            | Using 3/4 inch box wrench, remove.<br><b>There are four screws. Step 3 is typical for all four screws.</b>    |
| 4.                                     | Screws (9)  | Do step 3 for remaining three screws.   |
| 5. Curbside                            | Mount assembly (10)   | Remove.   |
| 6.                                     | Mount assembly (10)   | See paragraph 4-10 for installation.  |

**NOTE**

See paragraphs 4-29, 4-30, 4-31 for installation of electronic equipment racks.

4-34. REMOVING MOUNT ASSEMBLY. (CONT)

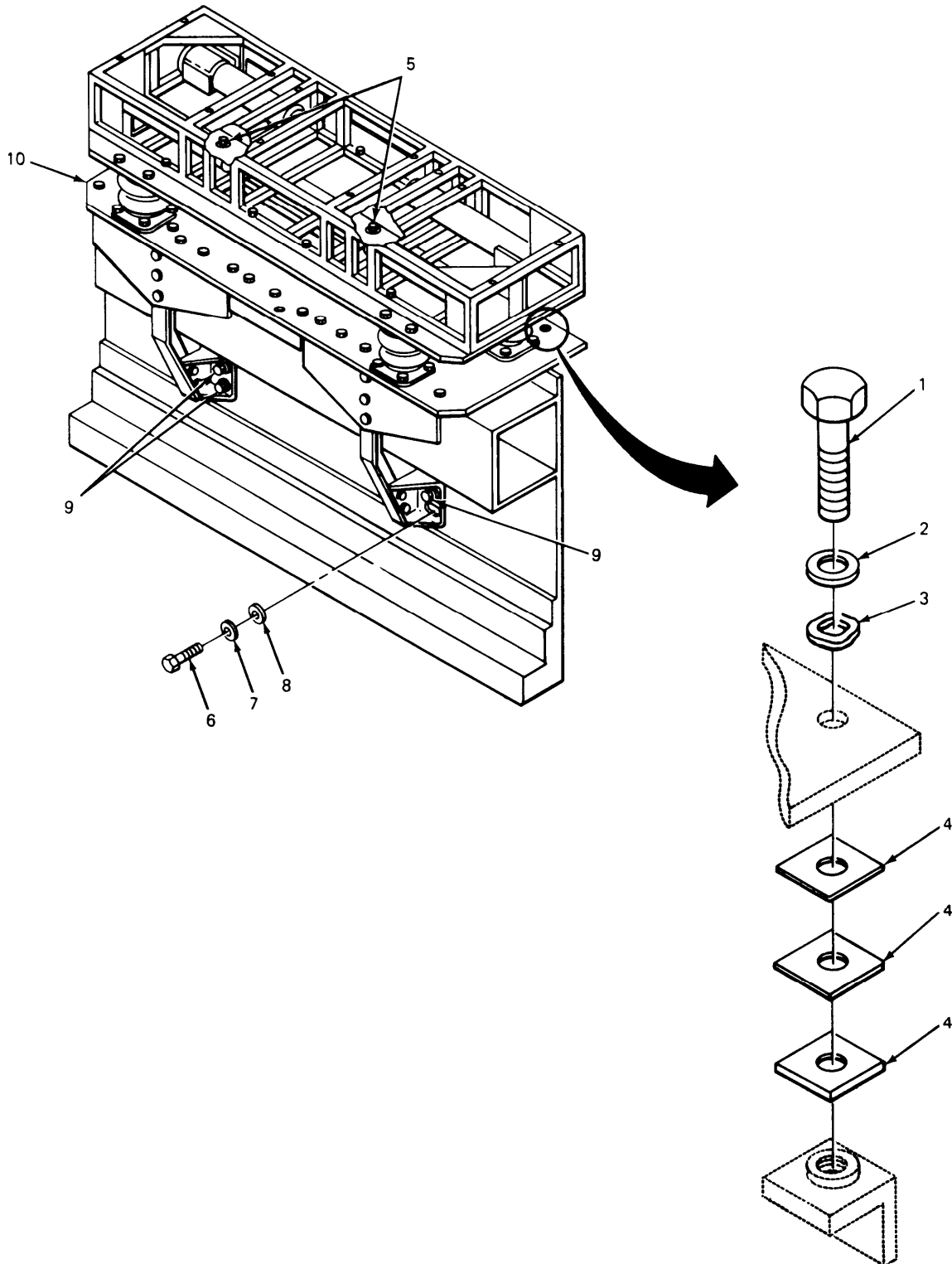

EL8KH044

**4-35. REMOVING/INSTALLING ELECTRONICS EQUIPMENT TABLE.**

This task covers:

1. Removal
2. Installation

**INITIAL SETUP**

Tools	Personnel Required
1/2 inch box wrench (2 required)	One mechanic
Materials/Parts	Equipment Condition
Electronic equipment table	Mount assembly removed. See paragraph 4-34.

LOCATION	ITEM	ACTION REMARKS
----------	------	-------------------

**REMOVAL**

1. Lower rails of electronic equipment table	Screw (1), flat washers (2) and nut (3)	Using two 1/2 inch box wrenches, remove. <b>There are eight screws. Step 1 is typical for all eight screws.</b>
2.	Screws (4)	Do step 1 for remaining seven screws.
3.	Electronic equipment table (5)	Remove. <b>For storage, put hardware in cloth bag, attach to electronic equipment table and store in original carton.</b>

**INSTALLATION**

1. Top plate assemble	Electronic equipment table (5) and top plate assembly (6)	Put electronic equipment table on top of top plate assembly and align holes.
2. Lower rails of electronic equipment table	Screw (1), flat washers (2) and nut (3)	Install, hand tighten. <b>There are eight screws. Step 2 is typical for all eight screws.</b>
3.	Screws (4)	Do step 2 for remaining seven screws.



4-35. REMOVING/INSTALLING ELECTRONICS EQUIPMENT TABLE. (CONT)

LOCATION	ITEM	ACTION REMARKS
INSTALLATION (CONT)		
4. Lower rails of electronic equipment table	Screw (1) and nut (3)	Using two 1/2 inch box wrenches, tighten. <b>There are eight screws. Step 4 is typical for all eight screws.</b>
5.	Screws (1) and nuts (3)	Do step 4 for remaining seven screws.

**NOTE**

See paragraph 4-34 for installation of mount assembly. See paragraph 4-29, 4-30, 4-31 for installation of electronic equipment racks.

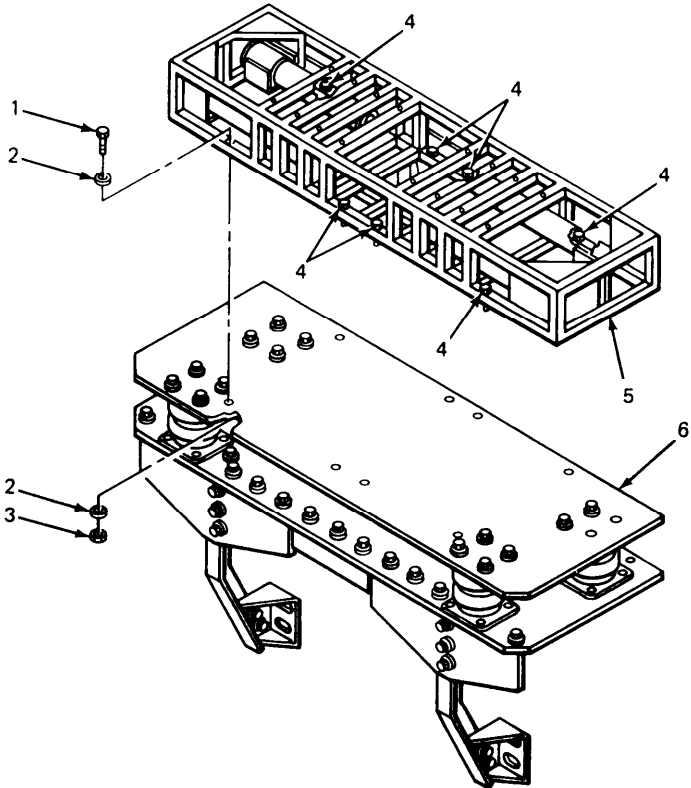

EL8KH045

**4-36. REMOVING TOP PLATE ASSEMBLY.**

This task covers:

Removal

INITIAL SETUP

Tools

9/16 inch box wrench (2 required)

Materials/Parts

Top plate assembly

Personnel Required

Two mechanics

Equipment Condition

Mount assembly removed. See paragraph 4-34. Electronic equipment table removed. See paragraph 4-35.

LOCATION	ITEM	ACTION REMARKS
----------	------	-------------------

**WARNING**

A helper will be needed to lift top plate assembly

- |    |   |   |
|----|---|---|
| 1. | Mount assembly<br>Screw (1), flat washers (2) and nut (3) | Using two 9/16 inch box wrenches, remove.<br><b>There are sixteen screws. Step 1 is typical for all sixteen screws.</b> |
| 2. | Screws (4)  | Do step 1 for remaining fifteen screws.   |
| 3. | Top plate assembly (5)                                    | Remove.   |
| 4. | Top plate assembly (5)                                    | See paragraph 4-9 for installation of top plate assembly.   |

**NOTE**

See paragraph 4-35 for installation of electronic equipment table.

4-36. REMOVING TOP PLATE ASSEMBLY. (CONT)

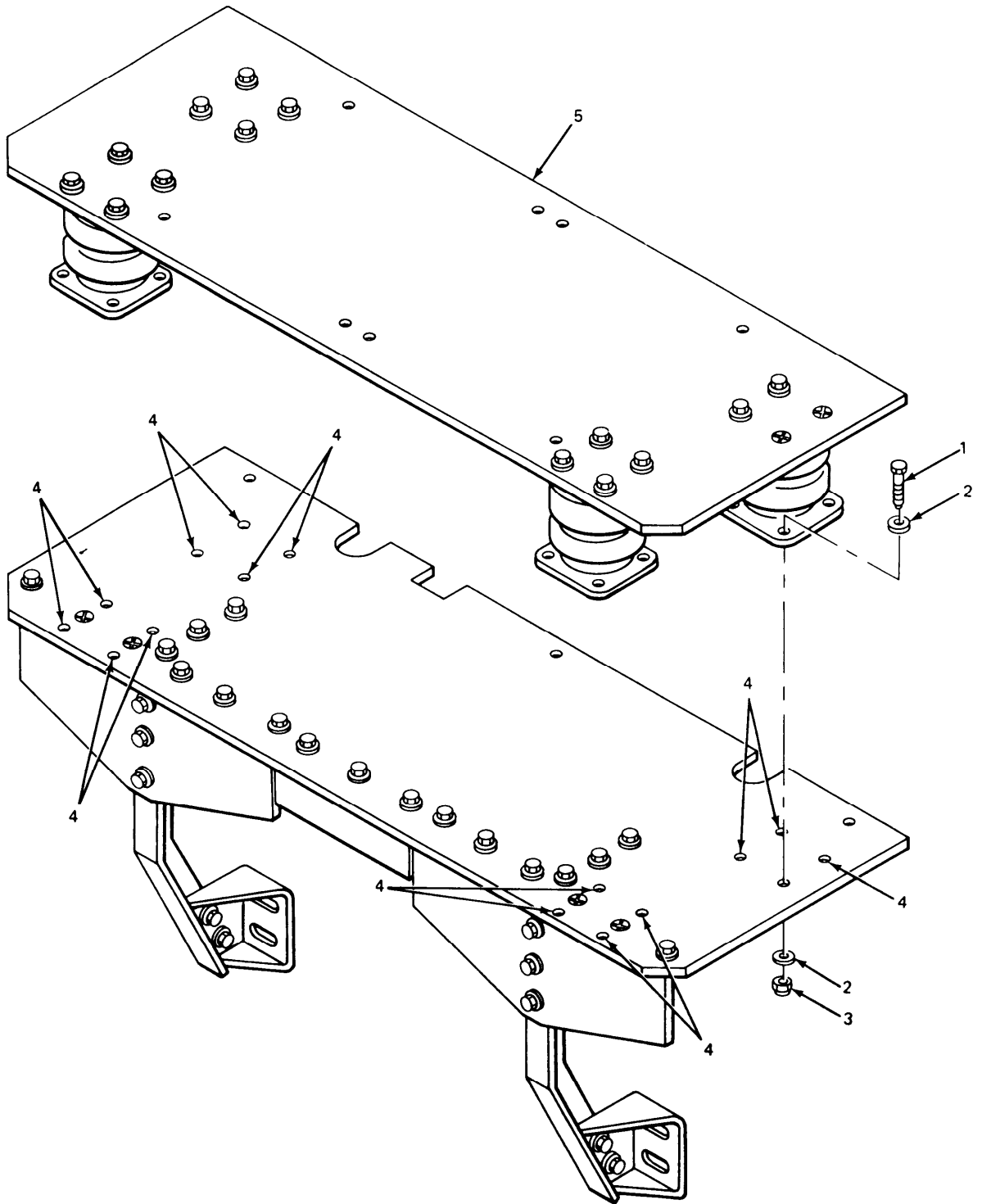

EL8KH046

**4-37. REMOVING/INSTALLING TOP PLATE TANDEM CUP ASSEMBLIES.**

This task covers:

1. Removal
2. Installation

**INITIAL SETUP**

Tools

Cross tip screwdriver  
 9/16 inch box wrench (2 required)

Materials/Parts

Tandem cup assemblies

Personnel Required

One mechanic

Equipment Condition

Top plate assembly removed.  
 See paragraph 4-36.

LOCATION

ITEM

ACTION  
 REMARKS

**REMOVAL**

- |    |                    |   |   |
|----|--------------------|---|---|
| 1. | Top plate assembly | Screw (1), flat washers (2) and nut (3) | Using two 9/16 inch box wrenches, remove.<br><b>There are fourteen screws. Step 1 is typical for all fourteen screws.</b>         |
| 2. |                    | Screws (4)                              | Do step 1 for remaining fifteen screws.   |
| 3. |                    | Tandem cup assemblies (5)               | Remove.   |
| 4. |                    | Screw (6), flat washer (7) and nut (8)  | Using cross tip screwdriver, and 9/16 inch box wrench, remove.<br><b>There are two screws. Step 4 is typical for both screws.</b> |
| 5. |                    | Screw (9)                               | Do step 4 again.  |
| 6. |                    | Tandem cup assembly (10)                | Remove.<br><b>For storage, put hardware in cloth bag, attach to tandem cup assembly and store in original carton.</b>             |

4-37. REMOVING/INSTALLING TOP PLATE TANDEM CUP ASSEMBLIES. (CONT)

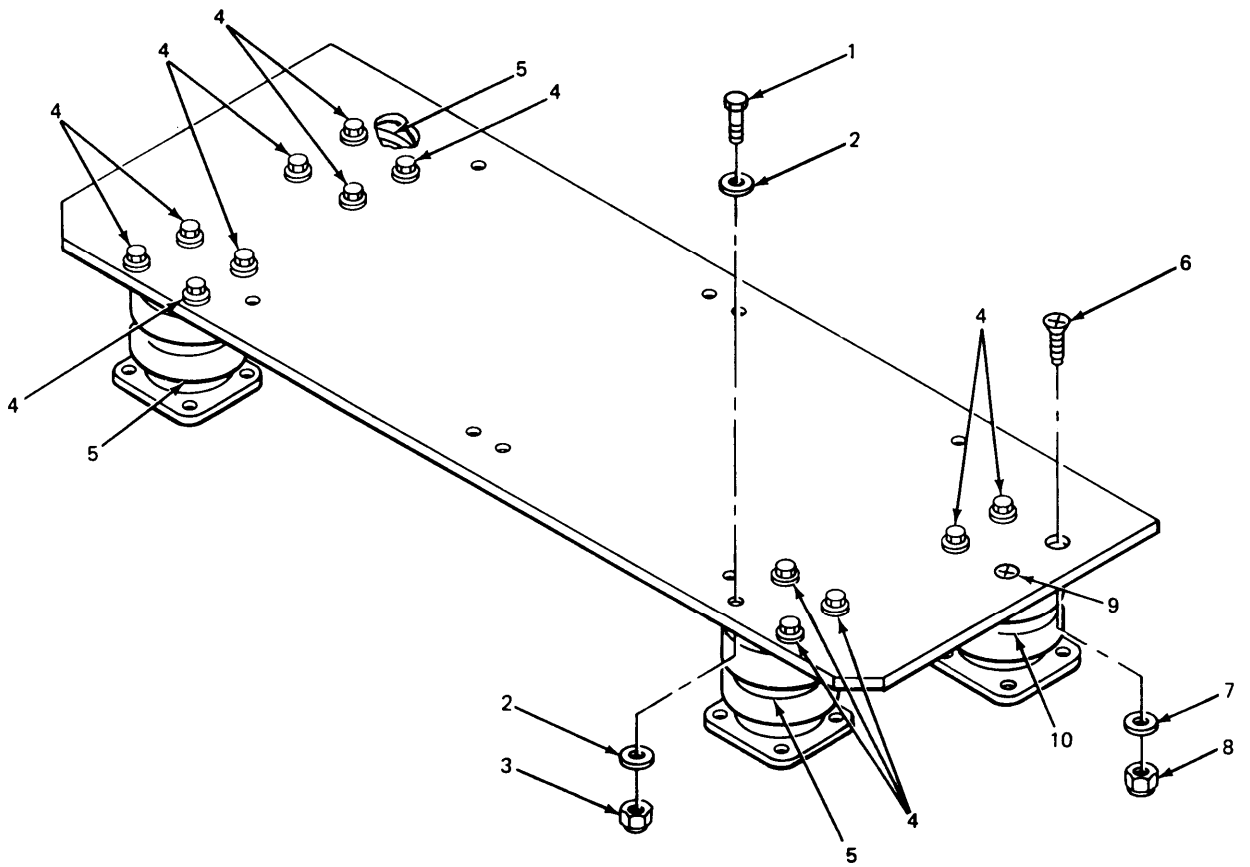

EL8KH047

4.37. REMOVING/INSTALLING TOP PLATE TANDEM CUP ASSEMBLIES. (CONT)

LOCATION	ITEM	ACTION REMARKS
INSTALLATION		
1. Outside of vehicle	Tandem cup assembly (1) and top plate (2)	Put tandem cup assembly on top plate and aline holes.
2.	Screw (3), flat washers (4) and nut (5)	Using two 9/16 inch box wrenches, install. <b>There are four screws. Step 2 is typical for all four screws.</b>
3.	Screws (6)	Do step 2 for remaining three screws.
4.	Tandem cup assemblies (7)	Do steps 1 thru 3 again for each tandem cup assembly.
5.	Tandem cup assembly (8) and top plate (2)	Put tandem cup on top plate and aline holes.
6.	Screw (9), flat washer (10) and nut (11)	Using cross tip screwdriver and 9/16 inch box wrench, install. <b>There are two screws. Step 5 is typical for both screws.</b>
7.	Screw (12)	Do step 5 again.
8.	Screw (13), flat washers (14) and nut (15)	Using two 9/16 inch box wrenches, install. <b>There are two screws. Step 7 is typical for both screws.</b>
9.	Screw (16)	Do step 7 again.

**NOTE**

See paragraph 4-36 for installation of top plate assembly.

4-37. REMOVING/INSTALLING TOP PLATE TANDEM CUP ASSEMBLIES. (CONT)

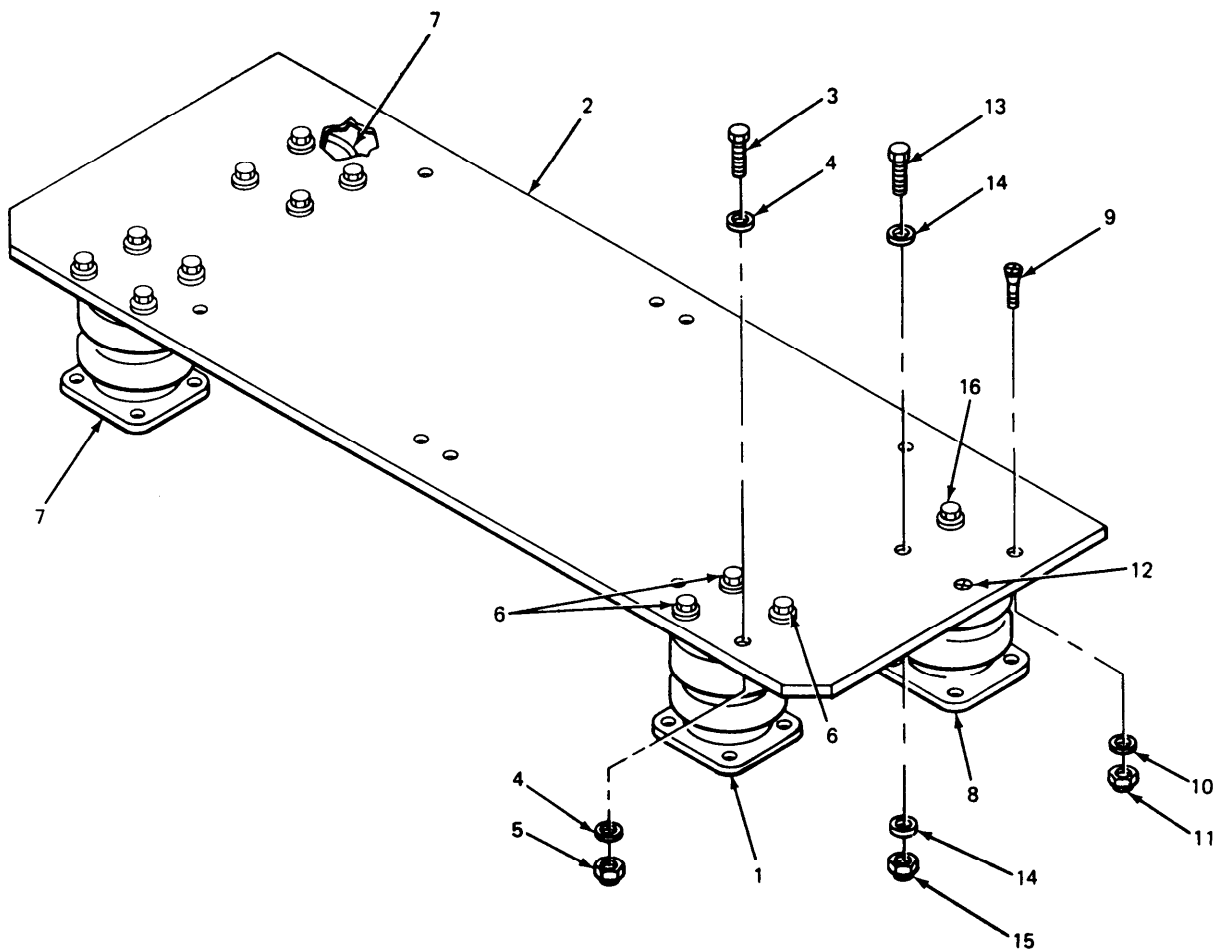

EL8KH048

**4-38. REMOVING/INSTALLING BOTTOM PLATE.**

This task covers:

1. Removal
2. Installation

**INITIAL SETUP**

Tools

- 9/16 inch box wrench (2 required)
- Cross tip screwdriver

Materials/parts

Bottom plate

Personnel Required

Two mechanics

Equipment Condition

Mount assembly removed. See paragraph 4-34. Electronic equipment table removed. See paragraph 4-35. Top plate assembly removed. See paragraph 4-36.

---

LOCATION	ITEM	ACTION REMARKS
----------	------	-------------------

---

REMOVAL

**NOTE**

A helper will be needed to lift bottom plate.

1. Bottom plate	Screw (1), flat washer (2) and nut (3)	Using cross tip screwdriver and 9/16 inch box wrench. remove. <b>There are four screws. Step 1 is typical for all four screws.</b>
2.	Screws (4)	Do step 1 for remaining three screws.
3.	Screw (5), flat washers (6) and nut (7)	Using two 9/16 inch box wrenches, remove. <b>There are seventeen screws. Step 3 is typical for all seventeen screws.</b>
4.	Screws (8)	Do step 3 for remaining sixteen screws.
5. Lower legs	Bottom plate (9)	Remove.



4-38. REMOVING/INSTALLING BOTTOM PLATE. (CONT)

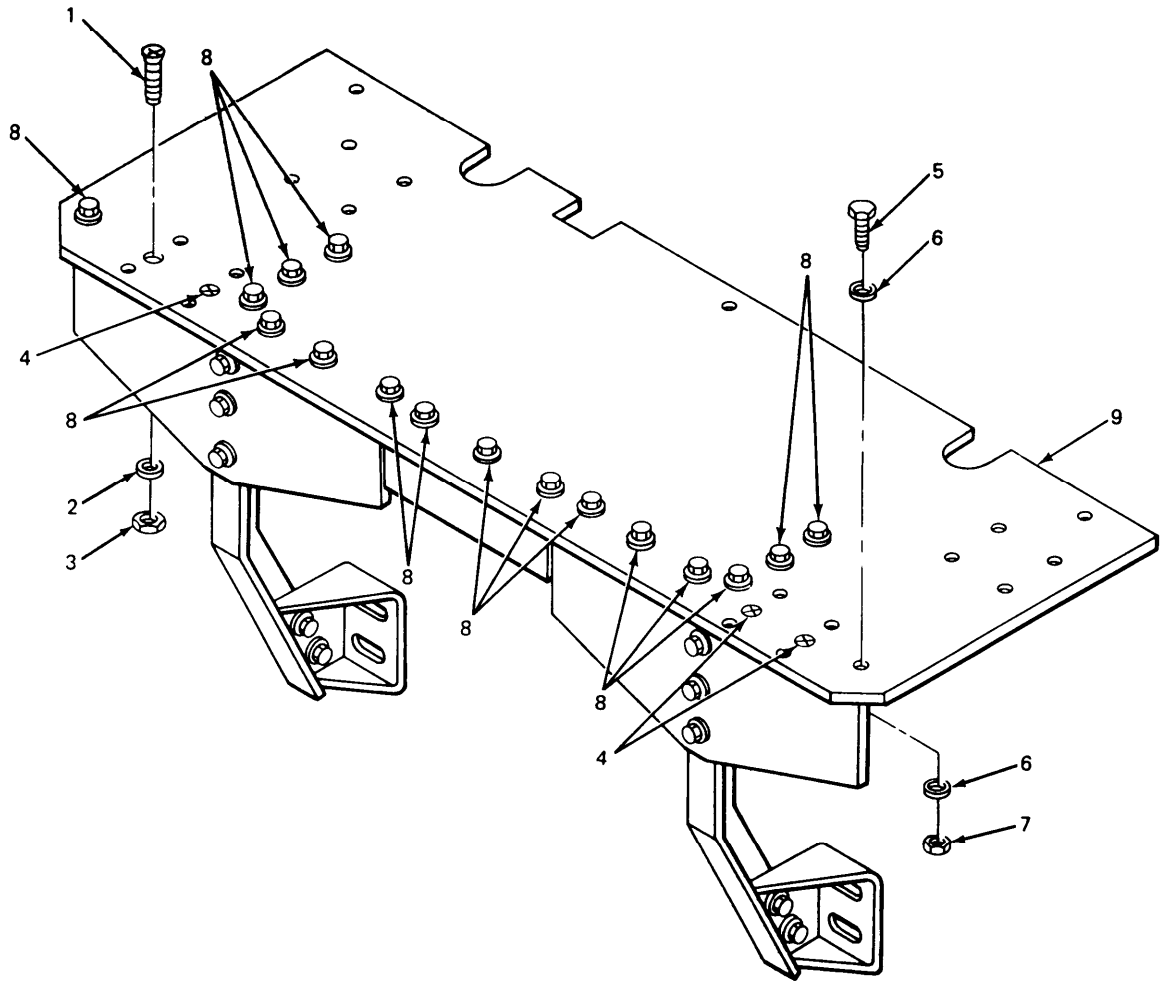

EL8KH049

4-38. REMOVING/INSTALLING BOTTOM PLATE. (CONT)

LOCATION	ITEM	ACTION REMARKS
INSTALLATION		
<b><u>WARNING</u></b>		
A helper will be needed to lift bottom plate.		
1. Outside of vehicle	Bottom plate (1) and lower legs (2)	Put bottom plate on top of lower legs and align holes.
2. Bottom plate and lower legs and supports	Screw (3), flat washer (4) and nut (5)	Using cross tip screwdriver, and 9/16 inch box wrench, install. <b>There are four screws. Step 2 is typical for all four screws.</b>
3.	Screws (6)	Do step 2 for remaining three screws.
4.	Screw (7), flat washers (8) and nut (9)	Using two 9/16 inch box wrenches, install. <b>There are seventeen screws. Step 4 is typical for all seventeen screws.</b>
5.	Screw holes (10)	Do step 4 again.

**NOTE**

See paragraph 4-9 for installation of top plate assembly.  
See paragraph 4-35 for installation of electronic equipment table.

4-38. REMOVING/INSTALLING BOTTOM PLATE. (CONT)

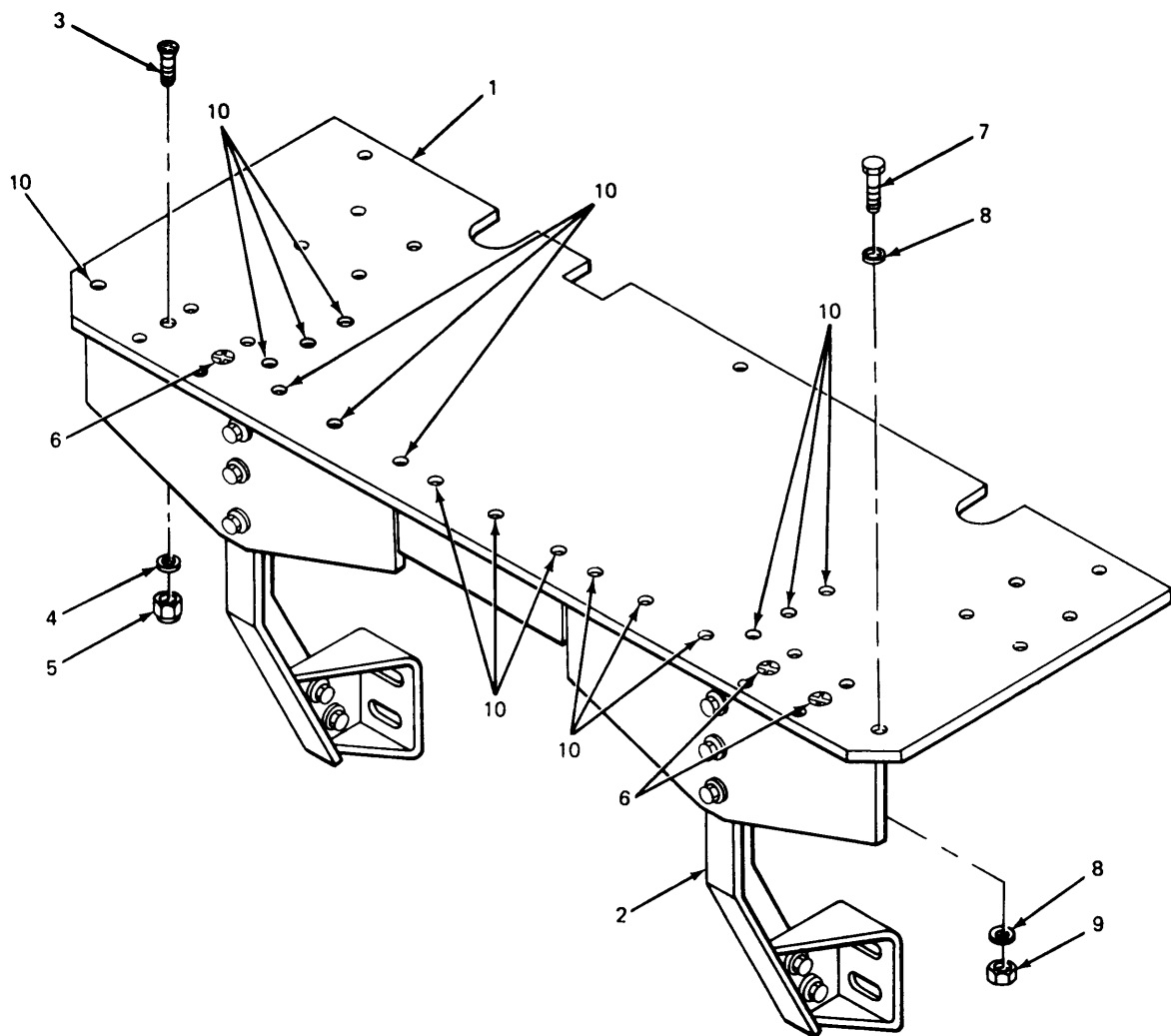

EL8KH050

**4-39. REMOVING/INSTALLING BOTTOM PLATE ASSEMBLY LOWER LEGS.**

This procedure is typical for the right or left lower leg.

This task covers:

1. Removal
2. Installation

**INITIAL SETUP**

Tools

- 9/16 inch box wrench (2 required)
- 1/2 inch box wrench (2 required)

Personnel Required

One mechanic

Materials/parts

Lower leg

Equipment Condition

Bottom plate assembly removed.  
See paragraph 4-38.

LOCATION

ITEM

ACTION  
REMARKS

**REMOVAL**

- |    |                       |  |   |
|----|-----------------------|--|---|
| 1. | Bottom plate assembly | Screw (1), flat washers (2) and nut (3)    | Using two 9/16 inch box wrenches, remove.<br><b>There are three screws. Step 1 is typical for all three screws.</b> |
| 2. |                       | Screws (4)                                 | Do step 1 again.  |
| 3. |                       | Screw (5), flat washers (6) and nut (7)    | Using two 1/2 inch box wrenches, remove.<br><b>There are three screws. Step 3 is typical for all three screws.</b>  |
| 4. |                       | Screws (8)                                 | Do step 3 again.  |
| 5. |                       | Lower leg (9)                              | Remove.   |
| 6. | Lower leg             | Screw (10), flat washers (11) and nut (12) | Using two 9/16 inch box wrenches, remove.<br><b>There are two screws. Step 4 is typical for both screws.</b>        |
| 7. |                       | Screw (13)                                 | Do step 4 again.  |
| 8. |                       | Support bracket (14)                       | Remove.   |

4-39. REMOVING/INSTALLING BOTTOM PLATE ASSEMBLY LOWER LEGS. (CONT)

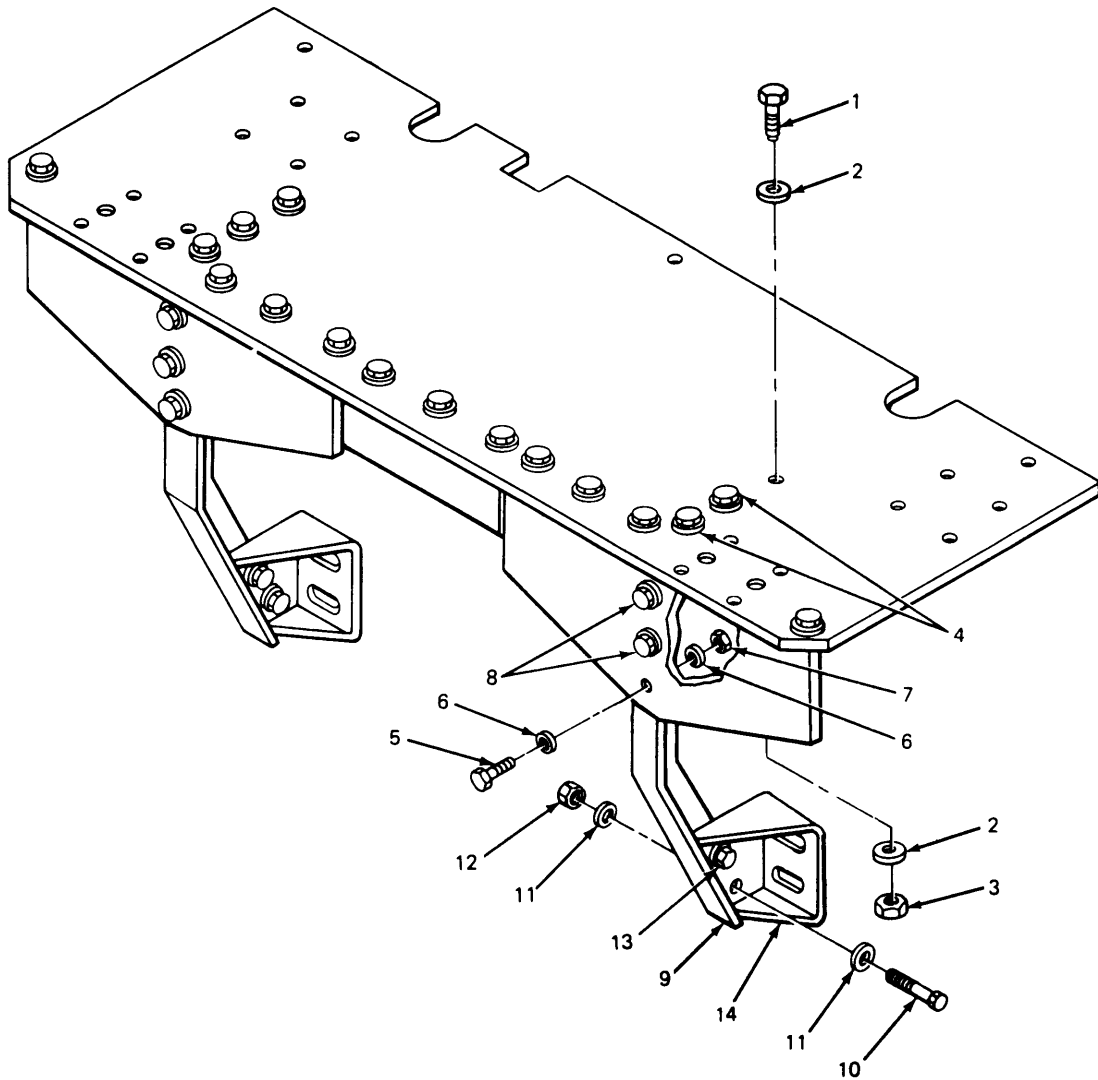

4-39. REMOVING/INSTALLING BOTTOM PLATE ASSEMBLY LOWER LEGS. (CONT)

LOCATION	ITEM	ACTION REMARKS
INSTALLATION		
1. Outside of vehicle	Support bracket (1) and lower leg (2)	Put support bracket on lower leg and aline holes.
2.	Screw (3), flat washers (4) and nut (5)	Using two 9/16 inch box wrenches, install. <b>There are two screws. Step 2 is typical for two screws.</b>
3.	Screw (6)	Do step 2 again.
4.	Lower leg (2) and bottom plate (7)	Put lower leg on bottom plate and aline holes.
5.	Screw (8), flat washers (9) and nut (10)	Using two 9/16 inch box wrenches, install. <b>There are three screws. Step 5 is typical for all three screws.</b>
6.	Screw holes (11)	Do step 5 again.
7.	Screw (12), flat washers (13) and nut (14)	Using two 1/2 inch box wrenches, install. <b>There are three screws. Step 7 is typical for all three screws.</b>
8.	Screws (15)	Do step 7 for remaining screws.

**NOTE**

See paragraph 4-9 for installation of top plate assembly.  
See paragraph 4-35 for installation of electronic equipment table.

4-39. REMOVING/INSTALLING BOTTOM PLATE ASSEMBLY LOWER LEGS. (CONT)

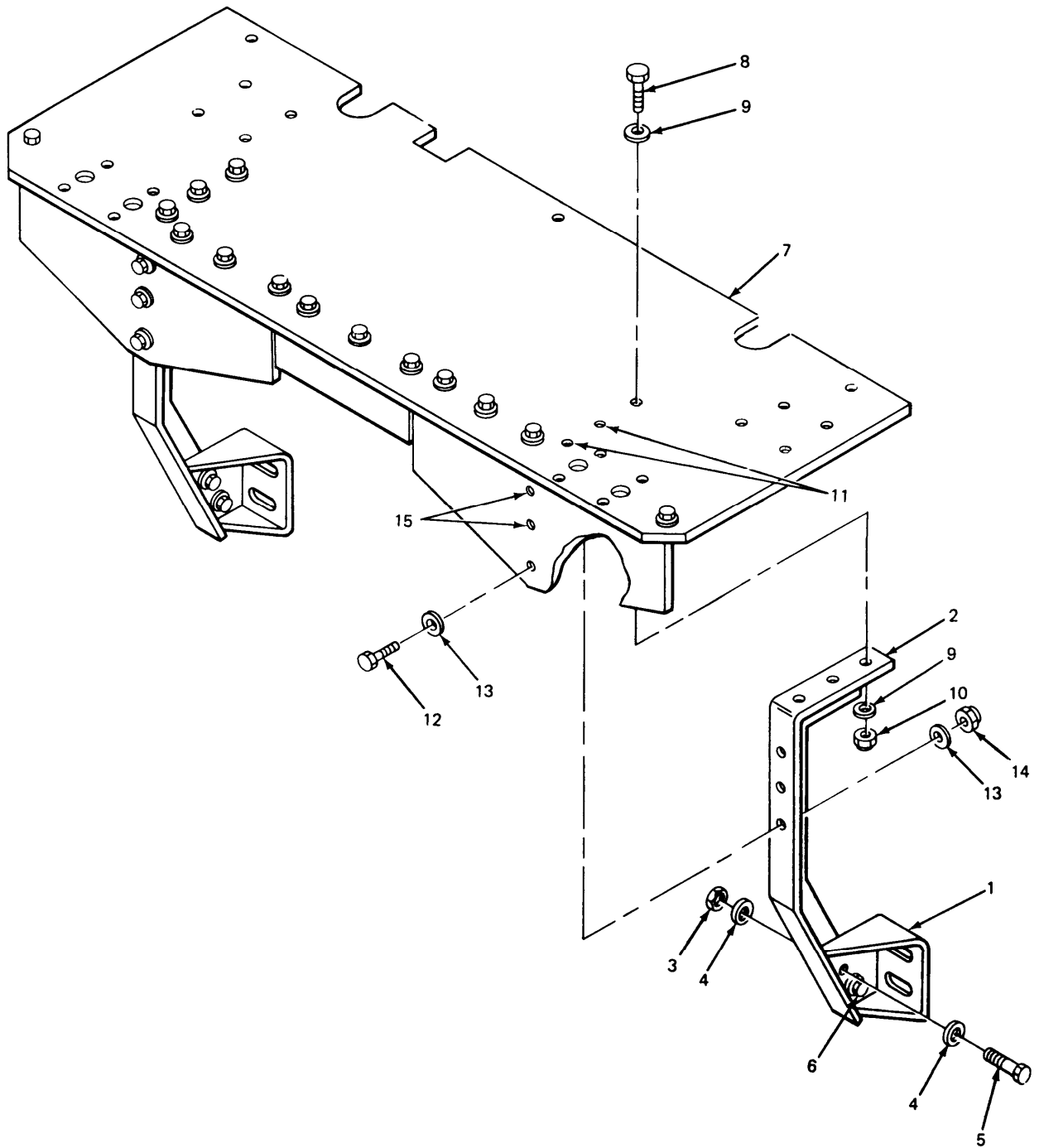

EL8KH052

**4-40. REMOVING 15 FOOT CABLE ASSEMBLY.**

This task covers:

Removal

INITIAL SETUP

Tools

Flat tip screwdriver

Materials/parts

15 foot cable assembly

Personnel Required

One mechanic

Equipment Condition

All power in vehicle off.

LOCATION	ITEM	ACTION REMARKS
1. Power receptacle	Connector plug and adapter (1)	Disconnect.
2. Roadside front to curbside rear	Cable support kit (2)	Remove. <b>Remove all cable clamps up to power distribution box.</b>
3. Rear of power distribution box	Connector (3)	Disconnect.
4. Roadside front to curbside rear	15 foot power cable (4)	Remove.
5.	15 foot power cable (4)	See paragraph 4-23 for installation.



4-40. REMOVING 15 FOOT CABLE ASSEMBLY. (CONT)

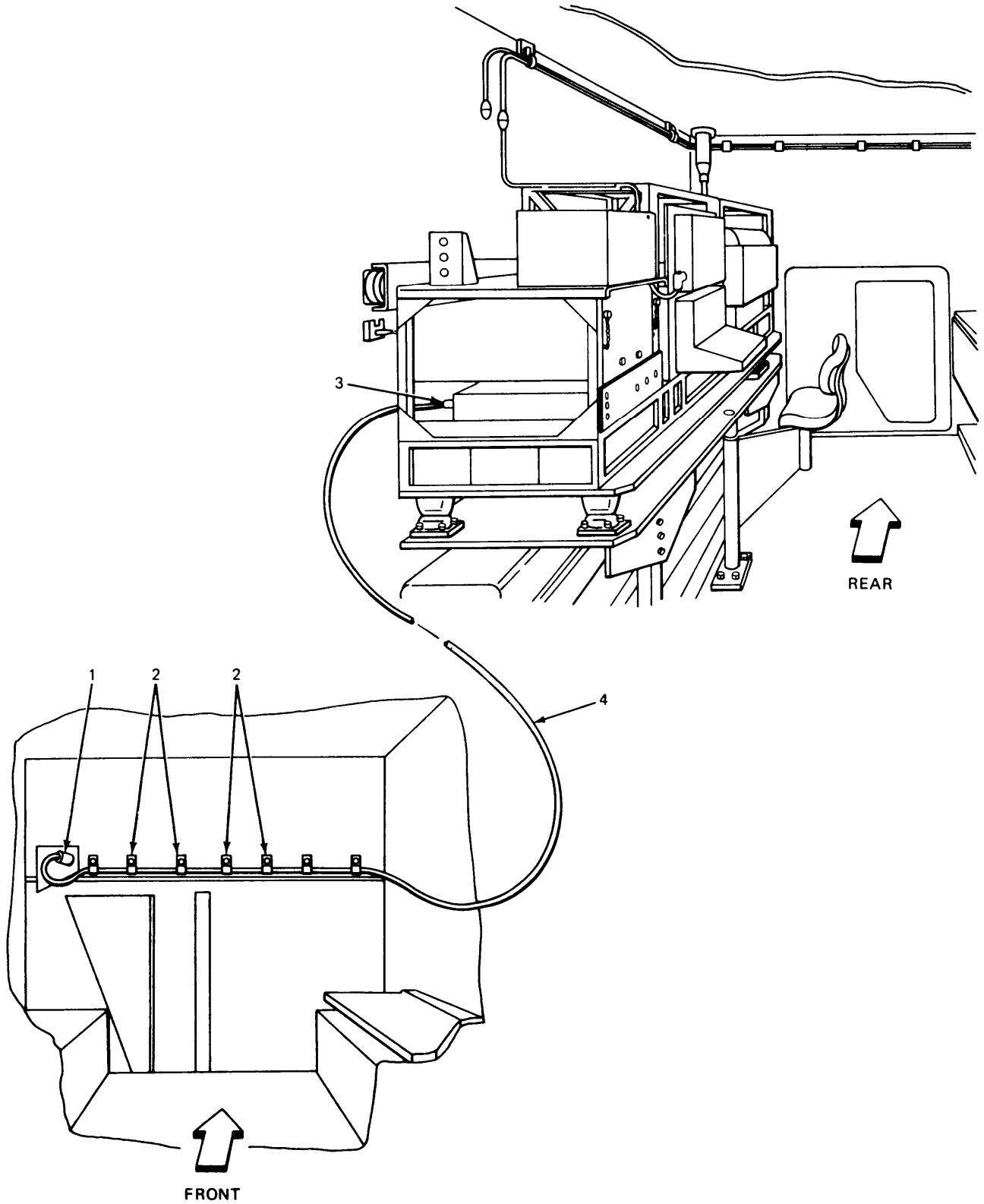

EL8KH053

**4-41. REMOVING/INSTALLING 6 INCH GROUND STRAP.**

This task covers:

1. Removal
2. Installation

**INITIAL SETUP**

**Tools**

- Flat tip screwdriver
- 9/16 inch box wrench
- Pliers

**Materials/parts**

- 6 inch ground strap

**Personnel Required**

One mechanic

**Equipment Condition**

All power in vehicle off.

LOCATION	ITEM	ACTION REMARKS
----------	------	-------------------

**REMOVAL**

1. Rear of power distribution box	Wingnut (1) and 6 inch ground strap (2)	Using pliers, remove.
2. Lower rear support key generator rack	Screw (3), IT lockwashers (4), nut (5) and 6 inch ground strap (2)	Using flat tip screwdriver and 9/16 inch box wrench, remove.
3. Rear of power distribution box	6 inch ground strap (2)	Remove. <b>For storage, put hardware in cloth bag, attach to 6 inch ground strap and pack in original carton.</b>

**INSTALLATION**

1. Rear of power distribution box	Wingnut (1) and 6 inch ground strap (2)	Using pliers, install.
2.	6 inch ground strap (2), screw (3), IT lockwashers (4) and nut (5)	Using flat tip screwdriver and 9/16 inch box wrench, install.

4-1. REMOVING/INSTALLING 6 INCH GROUND STRAP. (CONT)

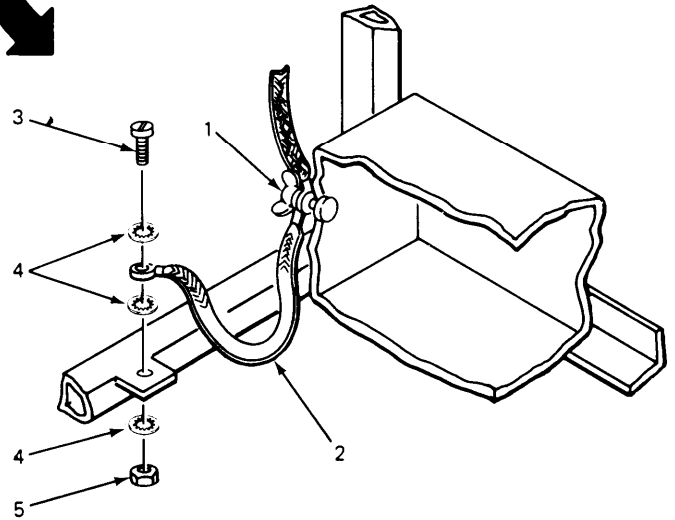
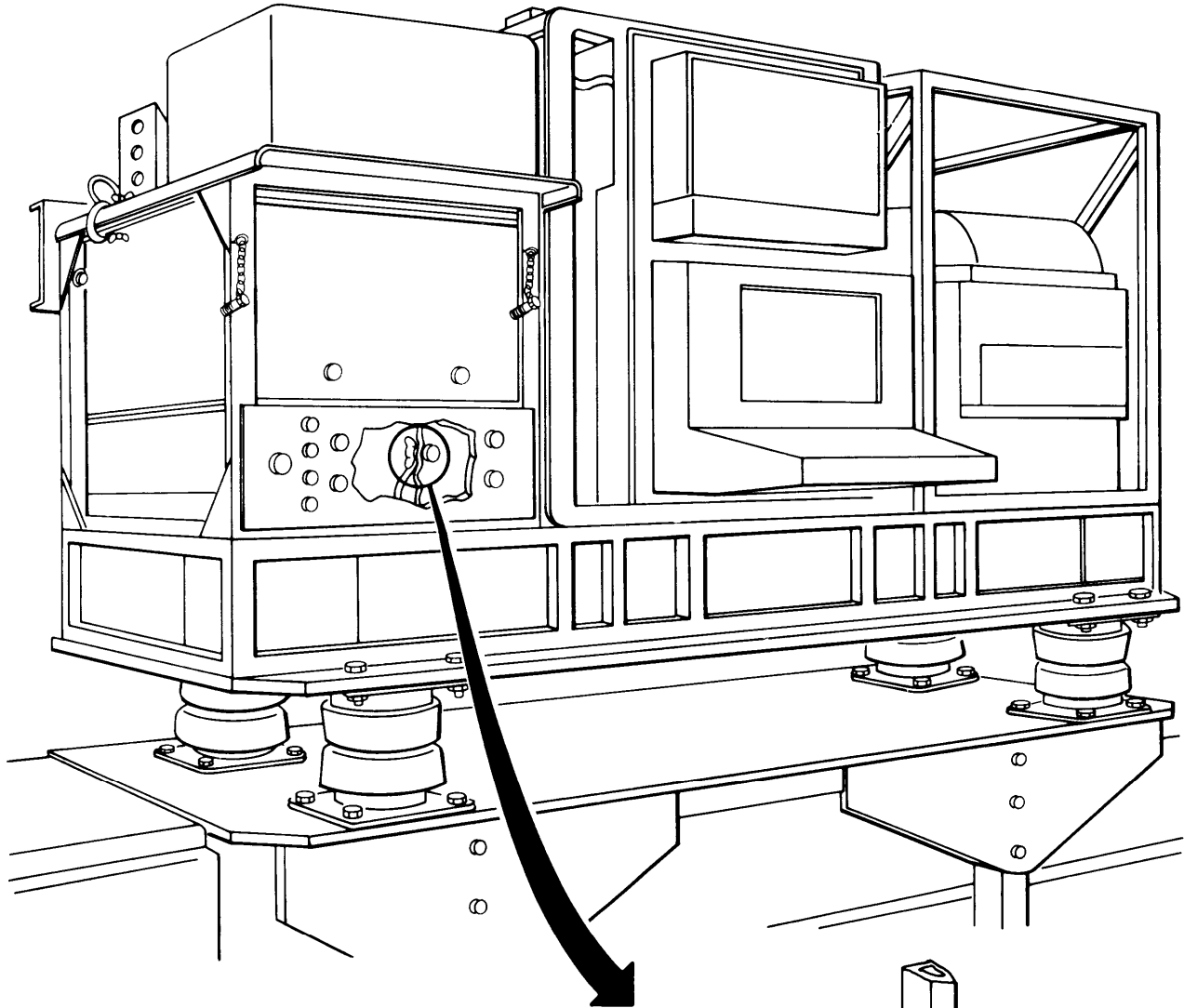

EL8KH054

**4-42. REMOVING/INSTALLING 15 INCH GROUND STRAP.**

This task covers:

1. Removal
2. Installation

**INITIAL SETUP**

Tools

- 9/16 inch box wrench (2 required)
- Pliers

Materials/Parts

- 15 inch ground strap

Personnel Required

One mechanic

Equipment Condition

All power in vehicle off.

LOCATION	ITEM	ACTION REMARKS
----------	------	-------------------

**REMOVAL**

- |                                   |   |   |
|-----------------------------------|---|---|
| 1. Rear of power distribution box | Wingnut (1) and 15 inch ground strap (2)                            | Using pliers, remove.   |
| 2. Curbside wall, support bracket | Screw (3), IT lockwashers (4), nut (5) and 15 inch ground strap (2) | Using flat tip screwdriver and 9/16 inch box wrench, remove.  |
| 3. Rear of power distribution box | 15 inch ground strap (5)  | Remove.<br><b>For storage, put hardware in cloth bag, attach to 15 inch ground strap and pack in original carton.</b> |

**INSTALLATION**

- |                                   |   |  |
|-----------------------------------|---|--|
| 1. Rear of power distribution box | Wingnut (1) and 15 inch ground strap (2)                            | Using pliers, install.                     |
| 2. Curbside wall, support bracket | 15 inch ground strap (2), screw (3), IT lockwashers (4) and nut (5) | Using two 9/16 inch box wrenches, install. |

4-42. REMOVING/INSTALLING 15 INCH GROUND STRAP. (CONT)

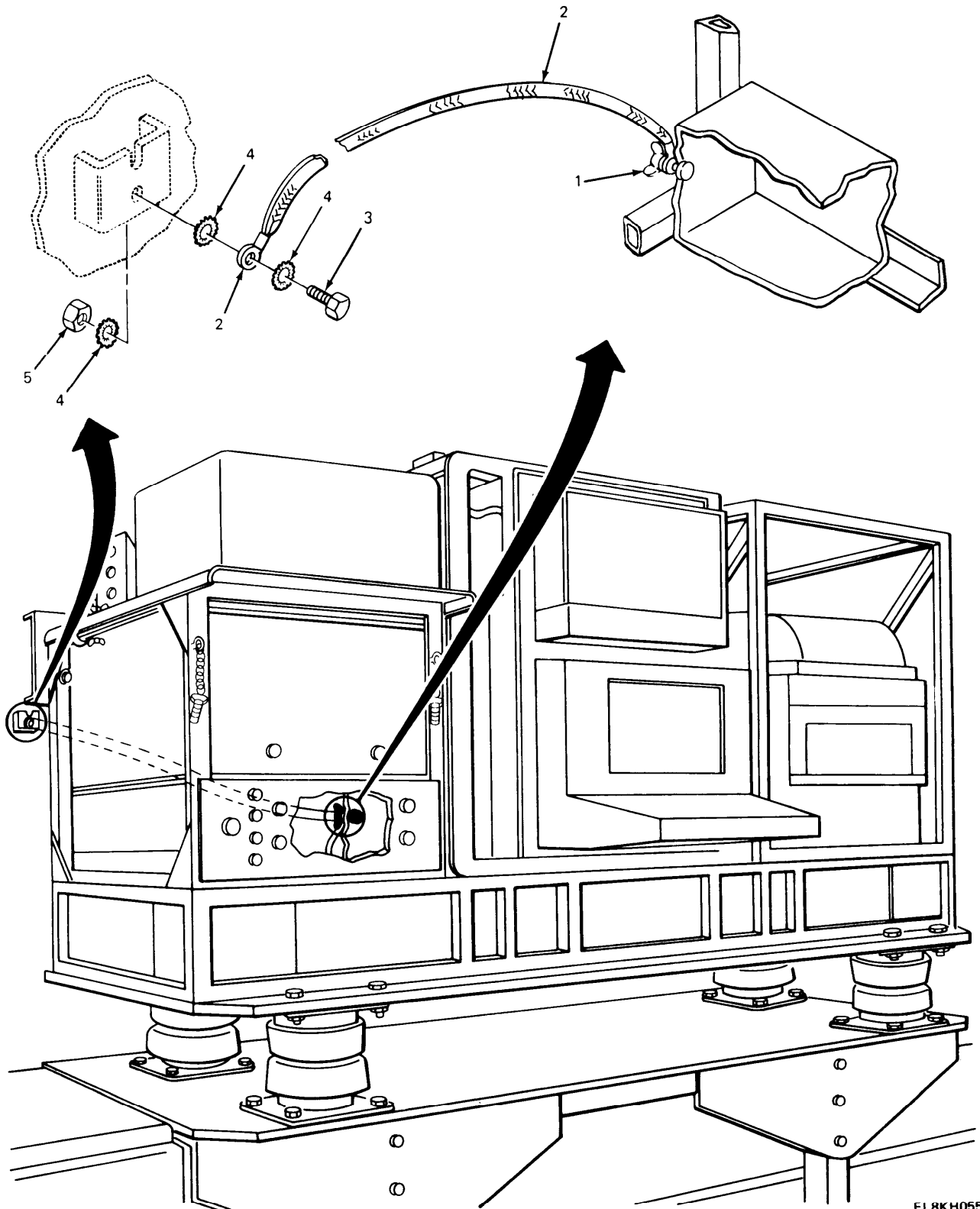

EL8KH055

**4-43. REMOVING W280 CABLE ASSEMBLY.**

This task covers:

Removal

INITIAL SETUP

Tools	Personnel Required
None	One mechanic
Materials/Parts	Equipment Condition
None	All power in vehicle off.

LOCATION	ITEM	ACTION REMARKS
----------	------	-------------------

**NOTE**

For single radio transmitter operation, disconnect W280 cable assembly from CX-13050/U cable assembly. When radio transmitters are used in retransmission mode, disconnect W280 cable assembly from CX-13088/U cable assembly.

1. Connector for CX-13050/U or CX-13088/U cable assemblies	Connector (1)	Disconnect.
2. Receptacle J6 on remote data terminal	Connector (2)	Disconnect. <b>Disconnect 90 degree elbow end.</b>
3. Message entry group rack	Nylon straps (3)	Remove.
4.	Cable assembly (4)	Remove.
5.	Cable assembly (4)	See paragraph 4-21 for installation.

4-43. REMOVING W280 CABLE ASSEMBLY. (CONT)

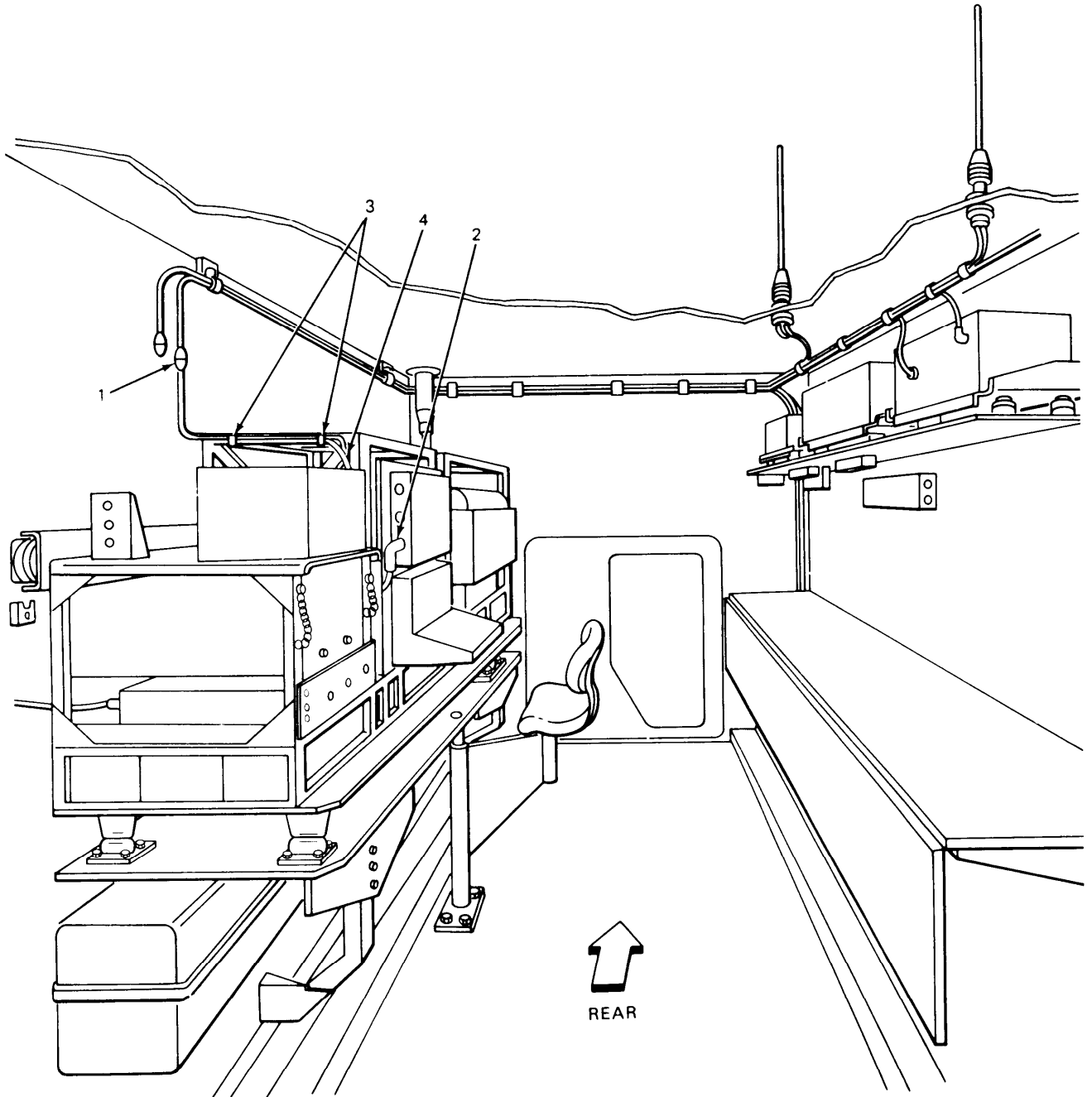

EL8KH056

**4-44. REMOVING CX-1305/U OR CX-13088/U CABLE ASSEMBLY.**

Removal procedures for CX-13050/U or CX-13088/U cable assemblies are the same.

This task covers:

Removal

**INITIAL SETUP**

Tools

Flat tip screwdriver

Personnel Required

One mechanic

Materials/parts

Cable Assembly CX-13050/U (16 feet)  
 Cable Assembly CX-13088/U (16 feet)

Equipment Condition

All power in vehicle off.

LOCATION

ITEM

ACTION  
 REMARKS

**NOTE**

When a single radio transmitter is used, remove Cable Assembly CX-13050/U. When radio transmitters are used in retransmission mode, remove Cable Assembly CX-13088/U.

- |                                |   |   |
|--------------------------------|---|---|
| 1. Radio receiver transmitters | Connector (1)   | Disconnect.   |
| 2.                             | Nylon straps (2)  | Remove.   |
| 3. Curbside upper wall         | Screw (3), cable clamp (4), IT lockwasher (5) and nut (6) | Using flat tip screwdriver, remove.<br><b>There are two support brackets to secure cables. Step 2 is typical for both support brackets.</b> |
| 4.                             | Support bracket (7)                                       | Do step 3 again.  |
| 5.                             | Connector (8)   | Disconnect.   |
| 6.                             | Cable assembly (9)  | Remove.   |
| 7.                             | Cable assembly (9)  | See paragraph 4-22 for installation.  |



4-44. REMOVING CX-13050/U OR CX-13088/U CABLE ASSEMBLY. (CONT)

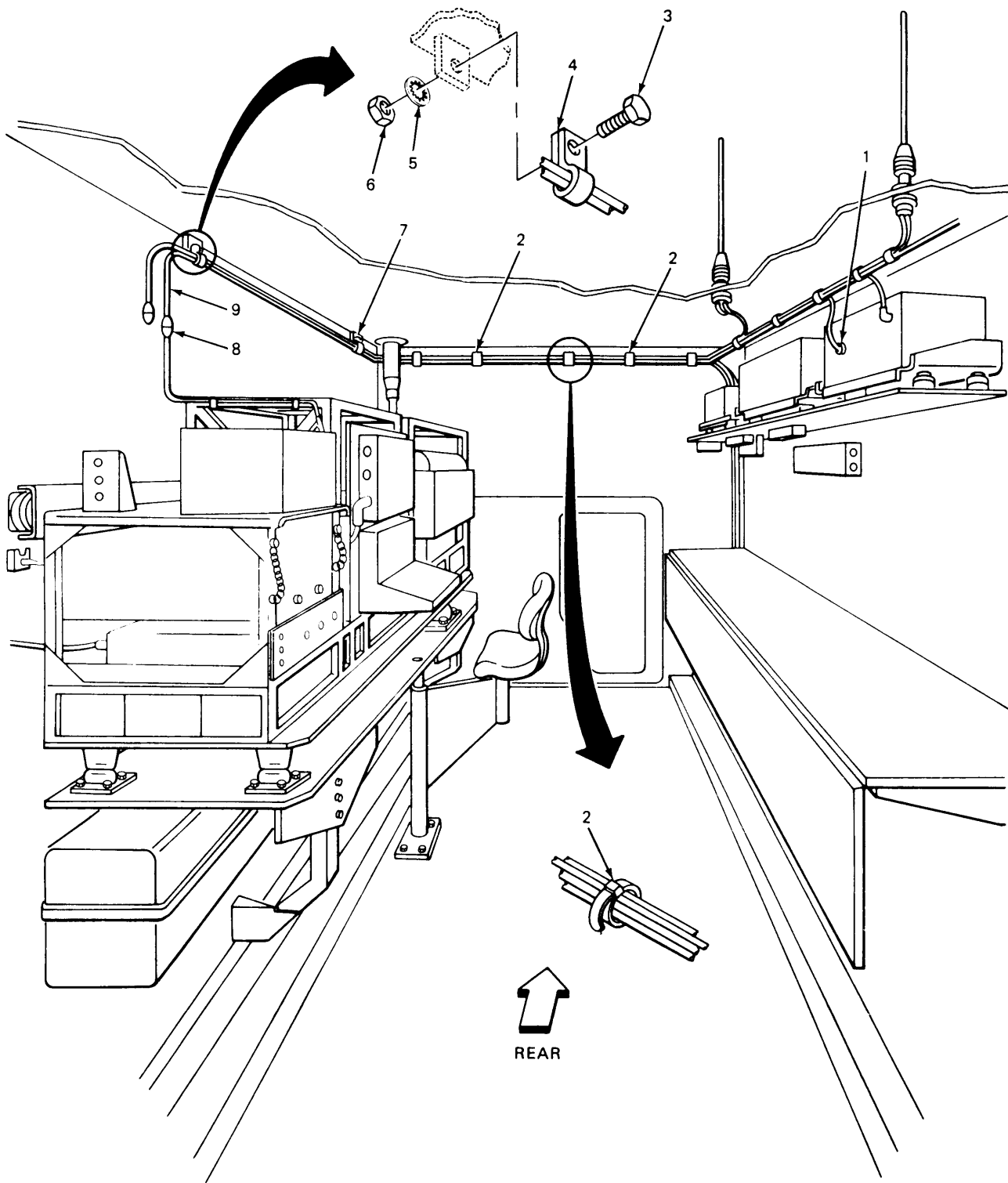

EL8KH057

**4-45. REMOVING/INSTALLING SEAT SUPPORT ASSEMBLY.**

This task covers:

1. Removal
2. Installation

INITIAL SETUP

Tools	Personnel Required
1/2 inch box wrench (2 required) 3/4 inch box wrench	One mechanic
Materials/Parts	Equipment Condition
Seat support assembly	Mount assembly installed.

LOCATION	ITEM	ACTION REMARKS
REMOVAL		
1. Curbside of vehicle	Quick release pin (1)	Remove.
2.	Seat (2)	Remove.
3.	Seat support assembly (3) and lower support (4)	Lift seat support assembly up and out of lower support, remove.
4. Floor plate	Screw (5) and washer (6)	Using 3/4 inch box wrench, remove. <b>There are four screws. Step 4 is typical for all four screws.</b>
5.	Screws (7)	Do step 4 for remaining three screws.
6. Curbside floor	Floor plate (8) and wood block (9)	Lift and insert wood block.
7. Floor plate	Screw (10) and nut (11)	Using two 1/2 inch box wrenches, remove. <b>There are four screws. Step 7 is typical for all four screws.</b>
8.	Screws (12)	Do step 7 for remaining three screws.
9.	Lower support (4)	Remove.

4-45. REMOVING/INSTALLING SEAT SUPPORT ASSEMBLY. (CONT)

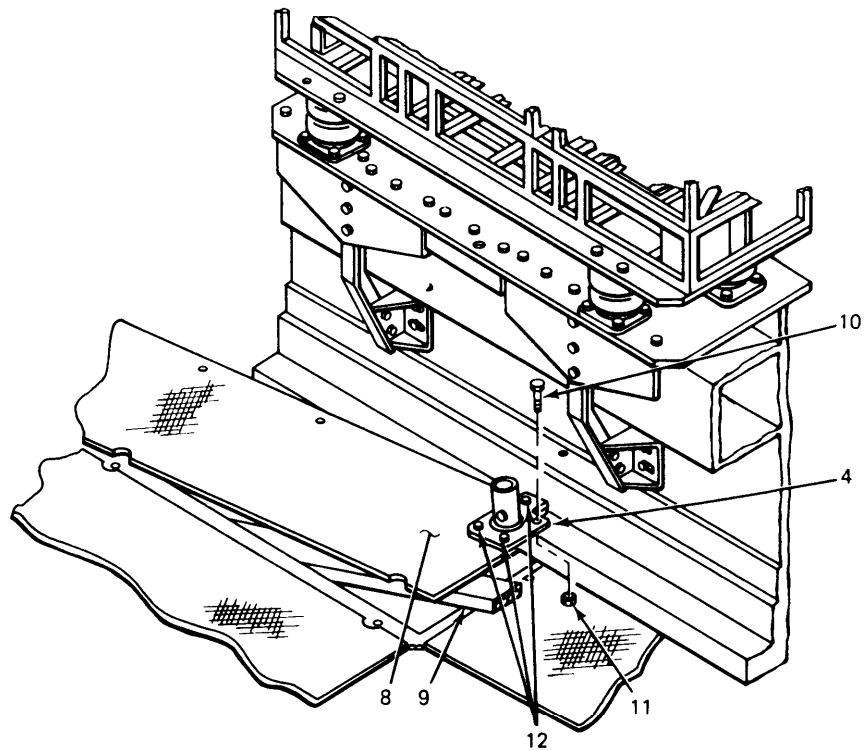
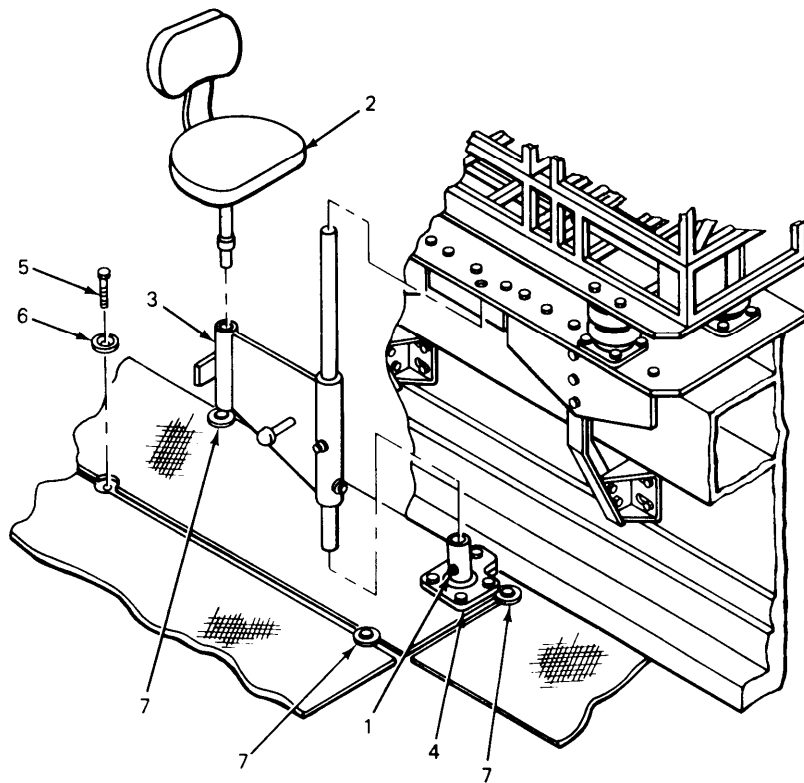

EL8KH058

4-45. REMOVING/INSTALLING SEAT SUPPORT ASSEMBLY. (CONT)

LOCATION	ITEM	ACTION REMARKS
INSTALLATION		
1. Outside of vehicle	Lower support (1) and floor plate (2)	Put lower support on floor plate and aline holes.
2. Floor plate	Screw (3) and nut (4)	Install, hand tighten. <b>There are four screws. Install screws with heads under floor plate. Step 2 is typical for all four screws.</b>
3.	Screw holes (5)	Do step 2 again.
4.	Screw (3) and nut (4)	Using two 1/2 inch box wrenches, tighten. <b>There are four screws. Step 4 is typical for all four screws.</b>
5.		Do step 4 for remaining three screws.
6. Curbside floor	Floor plate (2) and wood block (6)	Remove wood block and position floor plate.
7.	Screw (7) and flat washer (8)	Using 3/4 inch box wrench, install. <b>There are six screws. Step 7 is typical for all six screws.</b>
8.	Screws (9)	Do step 7 for remaining five screws.
9.	Seat support assembly (10) and lower support (1)	Install. <b>Put into mount assembly hole, then lower into lower support.</b>
10.	Seat (11)	Install.
11.	Quick release pin (12)	Install.

4-45. REMOVING/INSTALLING SEAT SUPPORT ASSEMBLY. (CONT)

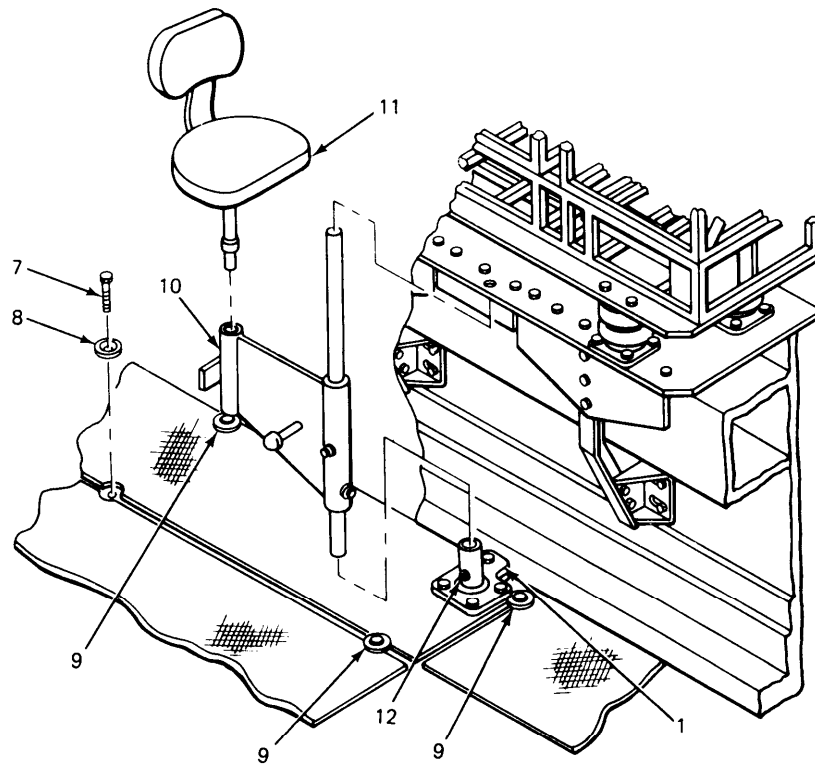
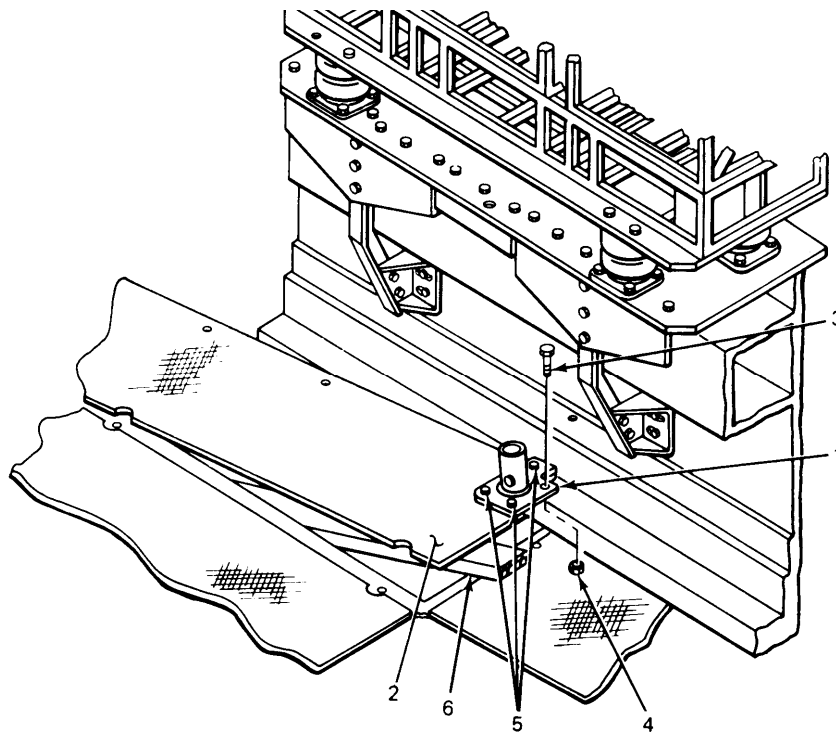

EL8KH059

**4-46. REMOVING /INSTALLING SAFETY BAR.**

This task covers:

1. Removal
2. Installation

**INITIAL SETUP**

Tools

9/16 inch box wrench (2 required)

Personnel Required

One mechanic

Materials/Parts

Safety bar

Equipment Condition

All power in vehicle off.

LOCATION	ITEM	ACTION REMARKS
----------	------	-------------------

**REMOVAL**

- |   |   |   |
|---|---|---|
| 1. Curbside front of top plate assembly | Screw (1), flat washers (2) and nut (3) | Using two 9/16 inch box wrenches, remove.<br><b>There are four screws. Step 1 is typical for all four screws.</b> |
| 2.                                      | Screws (4)                              | Do step 1 for remaining three screws.   |
| 3.                                      | Safety bar (5)                          | Remove.   |

**INSTALLATION**

- |   |   |  |
|---|---|--|
| 1. Curbside front of top plate assembly | Safety bar (5) and top plate assembly (6) | Put safety bar on top plate assembly and aline holes.  |
| 2.                                      | Screw (1), flat washers (2) and nut (3)   | Using two 9/16 inch box wrenches, install.<br><b>There are four screws. Step 2 is typical for all four screws.</b> |
| 3.                                      | Screws (4)                                | Do step 2 for remaining three screws.  |

4-46. REMOVING/INSTALLING SAFETY BAR. (CONT)

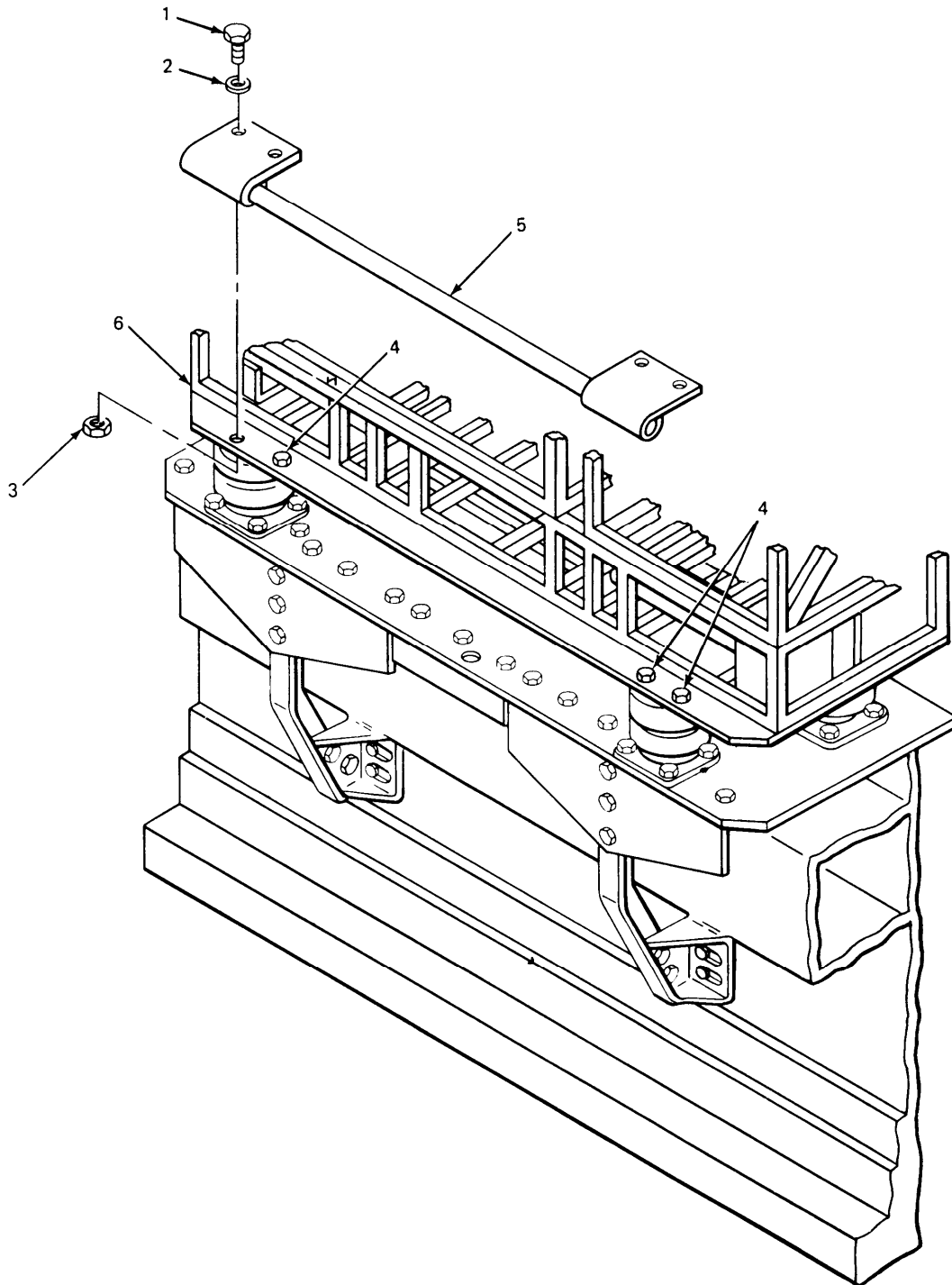

EL8KH060

**4-47. REMOVING EXTERNAL GROUND ROD KIT.**

This task covers:

Removal

**INITIAL SETUP**

Tools	Personnel Required
Flat tip screwdriver	One mechanic
8 pound sledge hammer	
Pliers	Equipment Condition
Materials/Parts	Ground rod installed.
None	

LOCATION	ITEM	ACTION REMARKS
1. Roadside, lower gusset	Wingnut (1), IT lockwashers (2) and 10 foot grounding strap (3)	Using pliers, remove.
2.	IT lockwashers (2) and wing- nut (1)	Using pliers, install.
5. Grounding Rod	Screws (4) and ground rod clamp (5)	Using flat tip screwdriver, remove.
4. Outside of vehicle	Grounding rod (6)	Using 8 pound sledge hammer, remove. <b>Hit grounding rod from side to side. Pour water over grounding rod to soften the ground. Continue to hit and pour water over grounding rod until it can be pulled from the ground.</b>

**NOTE**

The grounding rod comes in three sections. Uncouple the three sections and place in canvas bag with 10 foot ground strap and ground rod clamp. Store inside command carrier. See paragraph 4-25 for installation of ground rod kit.



4-47. REMOVING EXTERNAL GROUND ROD KIT. (CONT)

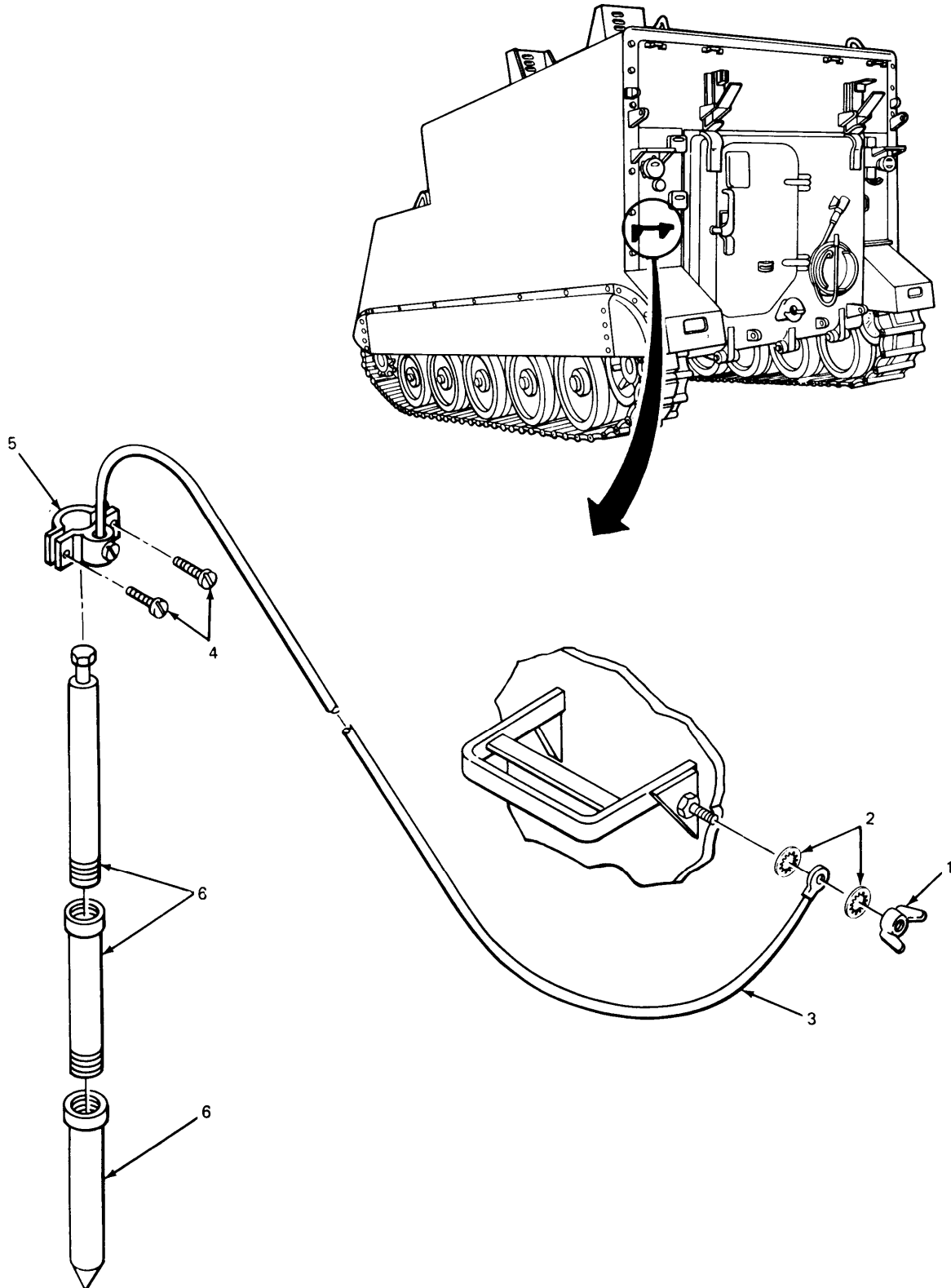

EL8KH061

## **Section VIII PREPARATION FOR STORAGE AND SHIPMENT**

Refer to SB 38-100 for preservation, packaging, packing and marking materials, supplies, and equipment used by the Army.

## CHAPTER 5

### DIRECT SUPPORT AND GENERAL SUPPORT MAINTENANCE

There are no direct support and general support maintenance procedures required for the Electronics Equipment Installation Kit MK-1531( )/GSG-10(V) in Command Post Carrier M577A1.



## APPENDIX A

### REFERENCE

**A-1. SCOPE.**

The following publications contain information applicable to the installation of Electronic Equipment Installation Kit MK-1 531( )/GSG-10(V) in Command Post Carrier M577A1.

**A-2. PAMPHLETS.**

Consolidated Index of Army Publications and Blank Forms .....	DA Pam 310-1
Report of Packaging and Handling Deficiencies .....	AR 700-58

**A-3. SUPPLY BULLETINS.**

Vehicular Radio Sets and Authorized Installations .....	SB 11-131
Printing and Preservation Supplies Available for Field Use for Electronics Command Equipment .....	SB 11-573
Preservation, Packaging, Packing and Marking Materials, Supplies, and Equipment Used by the Army .....	SB 38-100

**A-4. TECHNICAL BULLETINS.**

Field Instructions for Painting and Preserving Electronics Command Equipment, Including Camouflage Pattern Painting of Electrical Equipment Shelters .....	TB 43-0118
Safety Measures to be Observed when Installing and Using Whip Antennas, Field Type Masts Towers, Antennas, and Metal Poles that are used with Communication, Radar and Direction Finder Equipment. ....	TB SIG 291

**A-5. TECHNICAL MANUALS.**

Operator's Manual: Data Display Artillery, Battery AN/GSO-122(BDU) (NSN7010-01-017-3741) .....	TM 11-7440-251-10
Operator's Manual: Message Entry Device, Variable Format AN/GSC-21 (VFMED) (NSN7010-01-017-6967) .....	TM 11-7440-253-10-1
Operator's Manual: Message Entry Device, Variable Format, AN/GSC-21 (VFMED) (NSN 7010-01-017-6967) .....	TM 11-7440-253-10-2
Operator's Manual: Message Entry Device, Variable Format, AN/GSC-21 (VFMED) (NSN7010-01-017-6967) .....	TM 11-7440-253-10-3

**A-5. TECHNICAL MANUALS. (CONT)**

Operator's Manual: Message Entry Device, Variable Format, AN/GSC-21 (VFMED) (NSN 7010-01 -017-6967) .....	TM 11-7440-253-10-4
Operator's Manual: Message Entry Device Variable Format, AN/GSC-21 (VFMED) (NSN 7010-01-017-6967) .....	TM 11-7440-253-10-5
The Army Maintenance Management System (TAMMS) .....	TM 38-750
Administrative Storage of Equipment .....	TM 740-90-1
Procedures for Destruction of Electronics Materiel to Prevent Enemy Use (Electronics Command) .....	TM 750-244-2
Operator's Manual for Welding Theory and Application .....	TM 9-237

## APPENDIX B

### MAINTENANCE ALLOCATION CHART

#### Section I INTRODUCTION

##### **B-1. SCOPE.**

a. This section provides a general explanation of all maintenance and repair functions authorized at various maintenance categories.

b. The Maintenance Allocation Chart (MAC) in Section II designates overall authority and responsibility for the performance of maintenance functions on the identified end item or component. The application of the maintenance functions to the end item or component will be consistent with the capacities and capabilities of the designated maintenance categories.

c. Section III lists the tools and test equipment (both special tools and common tool sets) required for each maintenance function as referenced from Section II.

d. Section IV contains supplemental instructions and explanatory notes for a particular maintenance function.

##### **B-2. MAINTENANCE FUNCTIONS.**

Maintenance functions will be limited to and defined as follows:

a. Inspect. To determine the serviceability of an item by comparing its physical, mechanical, and/or electrical characteristics, with established standards through examination (e.g., by sight, sound, or feel).

b. Test. To verify serviceability by measuring the mechanical, pneumatic, hydraulic, or electrical characteristics of an item and comparing those characteristics with prescribed standards.

c. Service. Operations required periodically to keep an item in proper operating condition, i.e., to clean (includes decontaminate, when required), to preserve, to drain, to paint, or to replenish fuel, lubricants, chemical fluids, or gases.

d. Adjust. To maintain or regulate, within prescribed limits, by bringing into proper or exact position, or by setting the operating characteristics to specified parameters.

e. Aline. To adjust specified variable elements of an item to bring about optimum or desired performance.

f. Calibrate. To determine and cause corrections to be made or to be adjusted on instrument or test, measuring and diagnostic equipment used in precision measurement. Consists of comparisons of two instruments, one of which is a certified standard of known accuracy, to detect and adjust any discrepancy in the accuracy of the instrument being compared.

## **B.2. MAINTENANCE FUNCTIONS. (CONT)**

g. Remove/install. To remove and install the same item when required to perform service or other maintenance functions. Install may be the act of emplacing, seating, or fixing into position a spare, repair part, or module (component or assembly) in a manner to allow the proper functioning of a piece of equipment or system.

h. Replace. To remove an unserviceable item and install a serviceable counterpart in its place. 'Replace' is authorized by the MAC and is shown as the 3rd position code of the SMR code.

i. Repair. The application of maintenance services, including fault location/troubleshooting, removal/installation, and disassembly/assembly procedures, and maintenance actions to identify troubles and restore serviceability to an item by correcting specific damage, fault, malfunction, or failure in a part, subassembly, module (component or assembly), end item or system,

j. Overhaul. That maintenance effort (service or action) prescribed to restore an item to a completely serviceable/operational condition as required by maintenance standards in appropriate technical publications (i.e., DMWR). Overhaul is normally the highest degree of maintenance performed by the Army. Overhaul does not normally return an item to like new condition.

k. Rebuild. Consists of those services/actions necessary for the restoration of unserviceable equipment to a like new condition in accordance with original manufacturing standards. Rebuild is the highest degree of materiel maintenance applied to Army equipment. The rebuild operation includes the act of returning to zero those age measurements (hours/miles, etc) considered in classifying Army equipment/components.

## **B-3. EXPLANATION OF COLUMNS IN THE MAC, SECTION II.**

a. Column 1, Group Number. Column 1 lists functional group code numbers, the purpose of which is to identify maintenance significant components, assemblies, subassemblies, and modules with the next higher assembly. End item group number shall be '00'.

b. Column 2, Component/Assembly. Column 2 contains the names of components, assemblies, subassemblies, and modules for which maintenance is authorized.

c. Column 3, Maintenance Function. Column 3 lists the functions to be performed on the item listed in Column 2. For detailed explanation of these functions, see paragraph B-2.



**B-3. EXPLANATION OF COLUMNS IN THE MAC, SECTION II. (CONT)**

d. Column 4, Maintenance Category. Column 4 specifies, by the listing of a work time figure in the appropriate subcolumn(s), the category of maintenance authorized to perform the function listed in Column 3. This figure represents the active time required to perform that maintenance function at the indicated category of maintenance. If the number or complexity of the tasks within the listed maintenance function vary at different maintenance categories, appropriate work time figures will be shown for each category. The work time figure represents the average time required to restore an item (assembly, subassembly, component, module, end item, or system) to a serviceable condition under typical field operating conditions. This time includes preparation time (including any necessary disassembly/assembly time), troubleshooting/fault location time, and quality assurance/quality control time in addition to the time required to perform the specific tasks identified for the maintenance functions authorized in the Maintenance Allocation Chart. The symbol designations for the various maintenance categories are as follows:

- C - Operator or Crew
- O - Organizational Maintenance
- F - Direct Support Maintenance
- H - General Support Maintenance
- D - Depot Maintenance

e. Column 5, Tools and Equipment. Column 5 specifies, by code, those common tool sets (not individual tools) and special tools, TM DE, and support equipment required to perform the designated function.

f. Column 6, Remarks. This column shall, when applicable contain a letter code, in alphabetic order, which shall be keyed to the remarks contained in Section IV.

**B-4. EXPLANATION OF COLUMNS IN TOOL AND TEST EQUIPMENT REQUIREMENTS, SECTION III.**

a. Column 1, Reference Code. The tool and test equipment reference code correlates with a code used in the MAC, Section 11, column 5.

b. Column 2, Maintenance Category. The lowest category of maintenance authorized to use the tool or test equipment.

c. Column 3, Nomenclature. Name or identification of the tool or test equipment.

d. Column 4, National Stock Number. The national stock number of the tool or test equipment.

e. Column 5, Tool Number. The manufacturer's part number.

**B-5. EXPLANATION OF COLUMNS IN REMARKS, SECTION IV.**

- a. Column 1, Reference Code. The code recorded in column 6, Section II.
- b. Column 2, Remarks. This column lists information pertinent to the maintenance function being performed as indicated in the MAC, Section II.

**Section II MAINTENANCE ALLOCATION CHART FOR INSTALLATION  
KIT MK=1531( )/GSG-10(V)**

(1) GROUP NUMBER	(2) COMPONENT/ ASSEMBLY	(3) MAINTENANCE FUNCTION	(4) MAINTENANCE CATEGORY					(5) TOOLS AND EQPT	(6) REMARKS
			C	O	F	H	D		
00	Installation Kit MK 1531( )/ GSG-10(V)	Install		10.5				1 thru 4	
01	Tacfire Rack	Inspect	0.3					3,4	
		Service	0.3					1,2	
		Replace		0.1				1,2	
		Repair			1.5				
0101	Mount Assembly	Inspect	0.1						
		Service	0.2					3,4	
		Replace		2.0				1,2	
		Repair			2.75			1,2	
010101	Electronics Equipment Table	Inspect	0.1						
		Service	0.2					3,4	
		Replace		1.5				1,2	
		Repair			2.0			1,2	
010102	Top Plate Assembly	Inspect	0.1						
		Service	0.2					3,4	
		Replace		1.5				1,2	
		Repair			0.75			1,2	
01010201	Tandem Cup Assembly	Inspect	0.1						
		Service	0.2					3,4	
		Replace		2.5				1,2	
		Repair			0.75			1,2	
010103	Bottom Plate Assembly	Inspect	0.1						
		Service	0.2					3,4	
		Replace		0.5				1,2	
		Repair			0.75			1,2	

**Section II MAINTENANCE ALLOCATION CHART FOR INSTALLATION  
KIT MK-1531( )/GSG-10(V)**

(1) GROUP NUMBER	(2) COMPONENT/ ASSEMBLY	(3) MAINTENANCE FUNCTION	(4) MAINTENANCE CATEGORY					(5) TOOLS AND EQPT	(6) REMARKS
			C	O	F	H	D		
01010301	Brace	Inspect	0.1					3,4	
		Service	0.2					1,2	
		Replace		1.0				1,2	
		Repair			2.0				
0102	Wall Mounting Assembly	Inspect	0.1					3,4	
		Service	0.2					1,2	
		Replace		2.5				1,2	
		Repair			1.0			1,2	
010201	Tandem cups	Inspect	0.1					3,4	
		Service	0.2					1,2	
		Replace		3.0				1,2	
		Repair			1.5				
0103	Key Generator Rack	Inspect	0.1					3,4	
		Service	0.2					1,2	
		Replace		0.5				1,2	
		Repair			0.75				
0104	Message Entry Group Rack	Inspect	0.1					3,4	
		Service	0.2					1,2	
		Replace		0.5				1,2	
		Repair			0.75				
0105	Electronic Line Printer Rack	Inspect	0.1					3,4	
		Service	0.2					1,2	
		Replace		0.5				1,2	
		Repair			0.75				
02	Tacfire Components								A,B, C
0201	Electronic Line Printer								B,C
0202	Message Entry Group								B,C
0203	Key Generator								B,C

**Section III TOOL AND TEST EQUIPMENT REQUIREMENTS FOR INSTALLATION  
KIT MK-1531( )/GSG-10(V)**

TOOLS OR TEST EQUIPMENT REF CODE	MAINTENANCE CATEGORY	NOMENCLATURE	NATIONAL/NATO STOCK NUMBER	TOOL NUMBER
1	C, O,F,H	Tool Kit Mechanic	5180-00-754-0641	
2	C, O,F,H	No. 2 Common Organi- zational Maintenance Tool Kit	4910-00-754-0654	
3	C,O	Methyl Ethyl Ketone	6810-00-264-8983	
4	C,O	Cleaning Cloth		

**Section IV REMARKS**

REFERENCE CODE	REMARKS
A	See TM 11-5820-401-12
B	See TM11-7440-251-10
C	See TM 117440-253-10-1

## GLOSSARY

A collection of words or terms and their definitions are given in this section.

Word or Term	Definition
Aline	Arrange or bring into line.
Assembly	A collection of parts put together to make one major part.
Clockwise	Moving in the direction traveled by the hands of a clock.
Counterclockwise	Opposite the direction traveled by the hands of a clock.
Engaged	To apply, to make connection with.
External	Outside of subject.
Flush	Up against.
Hardware	Manufactured articles of metal, like lock-washers, flat washers, nuts, bolts.
Install	To put in place or position.
Mount	Frame or support.
Overview	A brief description.
Pilot drill	To make ready for final drilling.
Preparation	To make ready.
Purge	To clear or get rid of.
Shim	A piece of metal used between two items to level.
Route	To put in place on a specific path or course.
Stud	A headless screw.
Terminal lug	A device attached to the end of a wire or cable to make a connection.
Top off	To fill up.
Ventilate	To expose to air.
Visibility	The ability to be seen.



INDEX

Subject	Page
<b>A</b>	
Administrative storage . . . . .	1-2
Assembly and installation of electronic equipment kit . . . . .	4-5
<b>B</b>	
Bottom plate, installation . . . . .	4-102
removal . . . . .	4-100
Bottom plate assembly, installation . . . . .	4-102
removal . . . . .	4-100
Bottom plate assembly lower legs, installation . . . . .	4-106
removal . . . . .	4-104
<b>C</b>	
Cable assemblies, W280, installation . . . . .	4-54
removal . . . . .	4-114
CX-13088/U, installation . . . . .	4-56
removal . . . . .	4-116
CX-13050/U, installation . . . . .	4-56
removal . . . . .	4-116
Checking unpacked materiel . . . . .	4-4
Common tools and equipment . . . . .	B-1
Curbside personnel seat, removal . . . . .	4-8
<b>D</b>	
Description and use of operator's controls and indicators . . . . .	2-1
Destruction of army electronic materiel . . . . .	1-2

**INDEX (CONT)**

Subject	Page
<b>E</b>	
Electronic equipment table,	
installation . . . . .	4-30
removal . . . . .	4-92
Electronic line printer,	
installation . . . . .	4-48
removal . . . . .	4-68
Electronic line printer rack,	
installation . . . . .	4-76
removal . . . . .	4-74
Electronic line printer sliding tray,	
installation . . . . .	4-46
removal . . . . .	4-71
Equipment,	
capabilities and features . . . . .	1-5
location and description of major components . . . . .	1-7
purpose . . . . .	1-5
safety, care and handling . . . . .	1-6
Equipment capabilities and features . . . . .	1-5
Equipment description . . . . .	1-5
External ground rod kit,	
installation . . . . .	4-62
removal . . . . .	4-124
<b>F</b>	
<b>G</b>	
General information . . . . .	1-1
Ground rod kit,	
installation . . . . .	4-62
removal . . . . .	4-124
Ground strap	
15 inch,	
installation . . . . .	4-52
removal . . . . .	4-112
6 inch,	
installation . . . . .	4-52
removal . . . . .	4-110



**INDEX (CONT)**

Subject	Page
<b>H</b>	
How to use this manual . . . . .	i
<b>I</b>	
Installation,	
cable assembly W280 . . . . .	4-54
cable assemblies CX-13088/U and CX-13050/U . . . . .	4-56
ground strap,4 inch... . . . .	4-44
electronics equipment table to top plate assembly . . . . .	4-14
external ground rod kit . . . . .	4-62
key generator rack to electronic equipment table. . . . .	4-34
message entry group rack and electronic line printer rack to wall mounting assembly . . . . .	4-20
mount assembly. . . . .	4-16
rack and wall mounting assembly . . . . .	4-30
rivnuts. . . . .	4-10
safety bar . . . . .	4-60
seat support assembly . . . . .	4-36
tacfire components . . . . .	4-48
top plate assembly to bottom plate assembly. . . . .	4-12
6 inch and 15 inch ground straps . . . . .	4-52
15 foot cable assembly . . . . .	4-58
Introduction . . . . .	1-1
<b>J</b>	
<b>K</b>	
Key generator,	
installation . . . . .	4-48
removal . . . . .	4-68
Key generator rack,	
installation . . . . .	4-34
removal . . . . .	4-82
<b>L</b>	
Locating area for welding wall mounting assembly spacers . . . . .	4-24
Location and description of major components . . . . .	1-6

**INDEX (CONT)**

Subject	Page
<b>J</b>	
<b>M</b>	
Maintenance,	
forms, records and reports . . . . .	1-2
reports of maintenance and unsatisfactory equipment . . . . .	1-2
reports of packaging and handling deficiencies . . . . .	1-2
Maintenance allocation chart . . . . .	B-1
Maintenance procedures. . . . .	1-2
Message entry group,	
installation . . . . .	4-48
removal . . . . .	4-68
Message entry group rack,	
installation . . . . .	4-20
removal . . . . .	4-78
Mount assembly,	
installation . . . . .	4-30
removal . . . . .	4-90
<b>N</b>	
Nomenclature cross reference . . . . .	1-3
<b>O</b>	
Operating instructions . . . . .	2-1
Operator maintenance. . . . .	2-1
Operator preventive maintenance checks and services . . . . .	2-1
Organizational maintenance. . . . .	4-66
Organizational troubleshooting . . . . .	4-67
<b>P</b>	
Preparation for storage and shipment . . . . .	4-126
Preventive maintenance checks and services . . . . .	4-66
Principles of operation . . . . .	1-8
Purpose of installation kit . . . . .	1-5

## INDEX (CONT)

	Q	R	
Subject			Page
Racks,			
electronic equipment table,			
installation . . . . .			4-14
removal . . . . .			4-92
electronic line printer,			
installation . . . . .			4-20
removal . . . . .			4-74
key generator,			
installation . . . . .			4-34
removal . . . . .			4-82
message entry group			
installation . . . . .			4-20
removal . . . . .			4-78
References . . . . .			A-1
Removing,			
ground strap,4inch . . . . .			4-70
cable assembly W280 . . . . .			4-114
cable assembly CX-13050/U and CX-13088/U. . . . .			4-116
curbside personnel seat . . . . .			4-8
map board. . . . .			4-6
mount assembly. . . . .			4-90
rear curbside table. . . . .			4-10
tacfire components . . . . .			4-68
top plate assembly. . . . .			4-94
15 foot cable assembly . . . . .			4-108
Removing/installing,			
bottom plate . . . . .			4-100
bottom plate assembly lower legs . . . . .			4-104
electronic equipment table . . . . .			4-92
electronic line printer rack . . . . .			4-74
key generator rack . . . . .			4-82
message entry group rack . . . . .			4-78
safety bar . . . . .			4-122
seat support assembly . . . . .			4-122
top plate tandem cup assemblies . . . . .			4-96
wall mounting. . . . .			4-86
wall mounting tandem cup assemblies . . . . .			4-88
6 inch ground strap . . . . .			4-110
15 inch ground strap . . . . .			4-112
Repair parts special tools, TMDE, and support equipment . . . . .			4-1
Report of packaging and handling deficiencies . . . . .			1-2
Reporting equipment improvement recommendations. . . . .			1-2
Reports of maintenance and unsatisfactory equipment . . . . .			1-2
Rivnuts,			
installation . . . . .			4-12

INDEX (CONT)

Subject	Page
<b>S</b>	
Safety bar,	
installation . . . . .	4-59
removal . . . . .	4-122
Safety, care and handling . . . . .	1-8
Scope of manual . . . . .	1-1
Seat support assembly,	
installation . . . . .	4-36
removal . . . . .	4-118
Service upon receipt . . . . .	4-1
Special tools, TMDE and support equipment . . . . .	4-1
<b>T</b>	
Tacfire components,	
installation . . . . .	4-48
removal . . . . .	4-68
Top plate,	
installation . . . . .	4-14
removal . . . . .	4-94
Top plate assembly,	
installation . . . . .	4-14
removal . . . . .	4-94
Top plate tandem cup assembly,	
installation . . . . .	4-14
removal . . . . .	4-96
Troubleshooting procedures . . . . .	3-1
<b>U</b>	
Unpacking . . . . .	4-2
<b>V</b>	
<b>W</b>	
Wall mounting,	
installation . . . . .	4-22
removal . . . . .	4-86
Wall mounting assembly,	
installation . . . . .	4-22
removal . . . . .	4-88
Wall mounting assembly spacers,	
installation . . . . .	4-30

X,Y,Z

RECOMMENDED CHANGES TO EQUIPMENT TECHNICAL PUBLICATIONS



THEN... JOT DOWN THE DOPE ABOUT IT ON THIS FORM. CAREFULLY TEAR IT OUT. FOLD IT AND DROP IT IN THE MAIL!

SOMETHING WRONG WITH THIS PUBLICATION?

FROM (PRINT YOUR UNIT'S COMPLETE ADDRESS)  
 Commander  
 Stateside Army Depot  
 ATTN: AMSTA-US  
 Stateside, N.J. 07703

DATE SENT  
 10 July 1975

PUBLICATION NUMBER  
 TM 11-5840-340-12

PUBLICATION DATE  
 23 Jan 74

PUBLICATION TITLE  
 Radar Set AN/PRC-76

BE EXACT. PIN-POINT WHERE IT IS

PAGE NO	PARA-GRAPH	FIGURE NO	TABLE NO
2-25	2-28		
3-10	3-3		3-1
5-6	5-8		
		F03	

IN THIS SPACE TELL WHAT IS WRONG AND WHAT SHOULD BE DONE ABOUT IT:

Recommend that the installation antenna alignment procedure be changed throughout to specify a 2° IFF antenna lag rather than 1°.

REASON: Experience has shown that with only a 1° lag, the antenna servo system is too sensitive to wind gusting in excess of 25 knots, and has a tendency to rapidly accelerate and decelerate as it hunts, causing strain to the drive train. Hunting is minimized by adjusting the lag to 2° without degradation of operation.

Item 5, Function column. Change "2 db" to "3db."

REASON: The adjustment procedure the the TRANS POWER FAULT indicator calls for a 3 db (500 watts) adjustment to light the TRANS POWER FAULT indicator.

Add new step f.1 to read, "Replace cover plate removed in step e.1, above."

REASON: To replace the cover plate.

Zone C 3. On J1-2, change "+24 VDC to "+5 VDC."

REASON: This is the output line of the 5 VDC power supply. +24 VDC is the input voltage.

TEAR ALONG PERFORATED LINE.

PRINTED NAME, GRADE OR TITLE, AND TELEPHONE NUMBER  
 SSG I. M. DeSpirito 999-1776

SIGN HERE

DA FORM 2028-2  
 1 JUL 79

PREVIOUS EDITIONS ARE OBSOLETE.

P.S.--IF YOUR OUTFIT WANTS TO KNOW ABOUT YOUR RECOMMENDATION MAKE A CARBON COPY OF THIS AND GIVE IT TO YOUR HEADQUARTERS

FILL IN YOUR  
UNIT'S ADDRESS

FOLD BACK

DEPARTMENT OF THE ARMY

\_\_\_\_\_  
\_\_\_\_\_

OFFICIAL BUSINESS  
PENALTY FOR PRIVATE USE \$300

POSTAGE AND FEES PAID  
DEPARTMENT OF THE ARMY  
DOD 314



TEAR ALONG PERFORATED LINE

Commander  
US Army Communications-Electronics Command  
and Fort Monmouth  
ATTN: DRSEL-ME-MP  
Fort Monmouth, New Jersey 07703

RECOMMENDED CHANGES TO EQUIPMENT TECHNICAL PUBLICATIONS



THEN...JOT DOWN THE DOPE ABOUT IT ON THIS FORM. CAREFULLY TEAR IT OUT, FOLD IT AND DROP IT IN THE MAIL.

SOMETHING WRONG WITH THIS PUBLICATION?

FROM: (PRINT YOUR UNIT'S COMPLETE ADDRESS)

DATE SENT

PUBLICATION NUMBER

TM 11-7440-268-14

PUBLICATION DATE

PUBLICATION TITLE

MK-1531( )/GSG-10(V)

BE EXACT PIN-POINT WHERE IT IS

PAGE NO.	PARA-GRAPH	FIGURE NO.	TABLE NO.

IN THIS SPACE TELL WHAT IS WRONG AND WHAT SHOULD BE DONE ABOUT IT:

TEAR ALONG PERFORATED LINE

PRINTED NAME GRADE OR TITLE AND TELEPHONE NUMBER

SIGN HERE

DA FORM 2028-2  
1 JUL 79

PREVIOUS EDITIONS ARE OBSOLETE

P.S.--IF YOUR OUTFIT WANTS TO KNOW ABOUT YOUR RECOMMENDATION MAKE A CARBON COPY OF THIS AND GIVE IT TO YOUR HEADQUARTERS.

FILL IN YOUR  
UNIT'S ADDRESS

FOLD BACK

DEPARTMENT OF THE ARMY

POSTAGE AND FEES PAID  
DEPARTMENT OF THE ARMY  
DOD 314



OFFICIAL BUSINESS  
PENALTY FOR PRIVATE USE \$300

Commander  
US Army Communications-Electronics Command  
and Fort Monmouth  
ATTN: DRSEL-ME-MP  
Fort Monmouth, New Jersey 07703

TEAR ALONG PERFORATED LINE



RECOMMENDED CHANGES TO EQUIPMENT TECHNICAL PUBLICATIONS



THEN...JOT DOWN THE DOPE ABOUT IT ON THIS FORM. CAREFULLY TEAR IT OUT, FOLD IT AND DROP IT IN THE MAIL.

SOMETHING WRONG WITH THIS PUBLICATION?

FROM: (PRINT YOUR UNIT'S COMPLETE ADDRESS)

DATE SENT

PUBLICATION NUMBER

TM 11-7440-268-14

PUBLICATION DATE

PUBLICATION TITLE

MK-1531( )/GSG-10(V)

BE EXACT PIN-POINT WHERE IT IS

PAGE NO.	PARA-GRAPH	FIGURE NO.	TABLE NO.

IN THIS SPACE TELL WHAT IS WRONG AND WHAT SHOULD BE DONE ABOUT IT:

TEAR ALONG PERFORATED LINE

PRINTED NAME GRADE OR TITLE AND TELEPHONE NUMBER

SIGN HERE

FILL IN YOUR  
UNIT'S ADDRESS

FOLD BACK

DEPARTMENT OF THE ARMY

\_\_\_\_\_  
\_\_\_\_\_

OFFICIAL BUSINESS  
PENALTY FOR PRIVATE USE \$300

POSTAGE AND FEES PAID  
DEPARTMENT OF THE ARMY  
DOD 314



TEAR ALONG PERFORATED LINE

Commander  
US Army Communications-Electronics Command  
and Fort Monmouth  
ATTN: DRSEL-ME-MP  
Fort Monmouth, New Jersey 07703

RECOMMENDED CHANGES TO EQUIPMENT TECHNICAL PUBLICATIONS



THEN...JOT DOWN THE DOPE ABOUT IT ON THIS FORM. CAREFULLY TEAR IT OUT, FOLD IT AND DROP IT IN THE MAIL.

SOMETHING WRONG WITH THIS PUBLICATION?

FROM: (PRINT YOUR UNIT'S COMPLETE ADDRESS)

DATE SENT

PUBLICATION NUMBER

TM 11-7440-268-14

PUBLICATION DATE

PUBLICATION TITLE

MK-1531( )/GSG-10(V)

BE EXACT PIN-POINT WHERE IT IS

PAGE NO.	PARA-GRAPH	FIGURE NO.	TABLE NO.

IN THIS SPACE TELL WHAT IS WRONG AND WHAT SHOULD BE DONE ABOUT IT:

TEAR ALONG PERFORATED LINE

PRINTED NAME GRADE OR TITLE AND TELEPHONE NUMBER

SIGN HERE

DA FORM 2028-2  
1 JUL 79

PREVIOUS EDITIONS ARE OBSOLETE

P.S.--IF YOUR OUTFIT WANTS TO KNOW ABOUT YOUR RECOMMENDATION MAKE A CARBON COPY OF THIS AND GIVE IT TO YOUR HEADQUARTERS.

FILL IN YOUR  
UNIT'S ADDRESS

FOLD BACK

DEPARTMENT OF THE ARMY

\_\_\_\_\_  
\_\_\_\_\_

OFFICIAL BUSINESS  
PENALTY FOR PRIVATE USE \$300

POSTAGE AND FEES PAID  
DEPARTMENT OF THE ARMY  
DOD 314



TEAR ALONG PERFORATED LINE

Commander  
US Army Communications-Electronics Command  
and Fort Monmouth  
ATTN: DRSEL-ME-MP  
Fort Monmouth, New Jersey 07703

By Order of the Secretary of the Army:

Official:

ROBERT M. JOYCE  
*Major General, United States Army*  
*The Adjutant General*

E. C. MEYER  
*General, United States Army*  
*Chief of Staff*

DISTRIBUTION:

To be distributed in accordance with Special List.





